

AutoChem™ II 2920

Bibliography of Peer-Reviewed Papers Citing Use of Micromeritics' AutoChem with a Mass Spectrometer

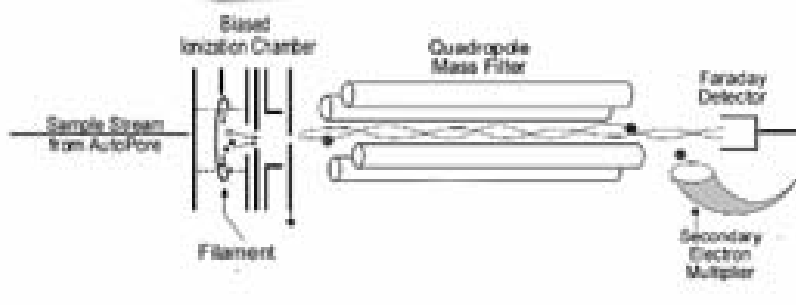

P.Webb
Feb. 2010

Citations of AutoChem / Mass Spectrometer Combinations

The list below was compiled from a search of technical papers in peer-reviewed journals. The search criteria were that the paper must cite the use of a Micromeritics AutoChem and also cite use of a mass spectrometer. These conditions do not necessarily mean that the mass spectrometer was connected directly to the AutoChem. Although that information sometimes can be determined from the excerpt (citation) or from the abstract, it most often requires that a full text version of the paper be obtained and the experimental section examined.

Title	Author / Publication	Citation	TPx
A bifunctional catalyst for the single-stage water–gas shift reaction in fuel cell ...	KG Azzam, IV Babich, K Seshan, L Lefferts - Journal of Catalysis, 2007	... Temperature-programmed reduction (H ₂ -TPR) studies were conducted in a Micromeritics AutoChem II 2920 device. Here, 1 g of catalyst was placed in a U-quartz tube and preheated to 300 °C, then cooled to –75 °C under Ar flow (20 ml/min). ...	2920
A combination of Ag/alumina and Ag modified ZSM-5 to remove NOx and CO ...	P Konova, K Arve, F Klingstedt, P Nikolov, A ... - Applied Catalysis B, ..., 2007	... Temperature programmed desorption of octane and propene over the most active catalysts was carried out using a volumetric equipment (AutoChem 2910, Micromeritics) combined with a quadruple <i>mass spectrometer</i> (Carlo Erba Instruments). ...	2910
A NEW METHOD FOR THE IN-SITU DIFFUSE REFLECTANCE FTIR ANALYSIS OF..	6-Mar	...minimizing sample size and maximizing throughput is best achieved using an elemental analyzer linked to an isotope ratio <i>mass spectrometer</i> (EA-IRMS). If fuel and thermal NOx can be quantified, this will be an important development to help guarantee combustor...	
A novel catalyst of CeO₂/Al₂O₃ for selective catalytic reduction of NO by NH₃	Y Shen, S Zhu, T Qiu, S Shen - Catalysis Communications, 2009	Total acidity measurement was evaluated by a temperature programmed desorption (TPD) of ammonia using an AUTOCHEM 2910 (Micromeritics). ... The ammonia desorption was monitored online by Thermo ONIX ProLab mass spectrometer. ...	2910
A novel route to the preparation of carbon supported nickel phosphide catalysts by ...dicp.ac.cn	L Ding, M Zheng, A Wang, T Zhang - Catalysis Letters	... The gaseous products during the synthesis were analyzed with an in situ <i>mass spectrometer</i> (Oministar, GSD-300). The chemisorption of CO was conducted on a Micromeritics AutoChem II 2910 automated catalyst characterization system. ...	2910
A pretreatment method of Ni/[gamma]-Al₂O₃ catalyst for naphthalene ...	F Li, X Yi, J Zheng, H Jin, W Fang - Catalysis Communications, 2009	... treated with a H ₂ /Ar = 10/90 mixture at 300 °C for 15 min, and the contrastive catalyst were carried out at 430 °C for 240 min on the Micromeritics AutoChem II 2920 ... Desorption gases were monitored by an online ThermoStar quadrupole <i>mass spectrometer</i> (model GSD301T2). ...	2920
A study of uranium oxide based catalysts for the oxidative destruction of short chain ...	SH Taylor, SR O'Leary - Applied Catalysis B, Environmental, 2000	...Hidden quadrupole <i>mass spectrometer</i> . Conversion data...levels using the <i>mass spectrometer</i> . Product selectivities...obtained using a Micromeritics 2910 AutoChem instrument. Typically...adsorption using a Micromeritics ASAP 2000 analyser...	2910
A study on nanosized cerium oxides systems for environmental catalysisdiva-portal.org [BOOK]	O Adamopoulos - 2003 - kth.diva-portal.org	... spectroscopy XANES X-ray absorption near edge structure EXAFS Extended x-ray absorption fine structure BET Brunauer-Emmit-Teller DLS Dynamic light scattering PSD Particle size distribution TEM Transmission electron microscopy MS <i>Mass spectrometer</i> Tign Ignition ...	

A surface and catalytic study of heterogenised Os₃(CO)₁₂ species in MCM-41 structures	Caps, V., Paraskevas, I., Tsang, S.C., Applied Catalysis A: General, 252 (1), p.37-49, Oct 2003	...2 O, CO, O ₂ , CO ₂) were monitored using a <i>mass spectrometer</i> . Its response was sampled every 6 s via a PE...Queen's University, Belfast) using an automated Micromeritics AutoChem 2910 . The samples were heated at a rate of 10...	2910
Abatement of CO from relatively simple and complex mixtures I. Oxidation on Pd- ...	AJ Dyakonov - Applied Catalysis B, Environmental, 2003	... in the 2 ml quartz pulse/flow reactor in an AutoChem 2910 catalyst characterization system from Micromeritics and also in a DSC/TG-111 calorimetric-gravimetric setup from Setaram. Reaction gases were analyzed by means of a ThermoStar mass-spectrometer from Balzers ...	2910
Abatement of CO from relatively simple and complex mixtures II.	Dyakonov, A.J., Little, C.A., Applied Catalysis B, Environmental, 67 (1), p.52-59, Sep 2006	...flow-through reactor (AutoChem 2910, Micromeritics), pretreated in...catalytic oxidation The AutoChem 2910 catalysis system...with ThermoStar mass-spectrometer were used to study...by a ThermoStar <i>mass spectrometer</i> from Balzers. The...	2910
Abatement of CO from relatively simple and complex mixtures III. Oxidation on Pd- ...	AJ Dyakonov, CA Little - Applied Catalysis B, Environmental, 2006	... Study of catalytic oxidation. The AutoChem 2910 catalysis system from Micromeritics coupled with ThermoStar mass-spectrometer were used to study the activity of the CeO ₂ /C and Pd/CeO ₂ catalysts in a 50 ml/min model gas mixture of 3% CO + 10% O ₂ in He. ...	2910
Active sites in HZSM-5 with low Fe content for the formation of surface oxygen by ...epfl.ch	L Kiwi-Minsker, DA Bulushev, A Renken - Journal of Catalysis, 2003	... The determination of the concentration of active sites, reactivity, and temperature-programmed (TPD) studies were performed in a Micromeritics AutoChem 2910 analyzer provided with a quartz plug-flow reactor. A ThermoStar 200 (Pfeiffer Vacuum) <i>mass spectrometer</i> was used ...	2910
Adsorption of CO₂ on molecular sieves and activated carbonanl.gov	RV Siriwardane, MS Shen, EP Fisher, JA Poston - Energy Fuels, 2001	... The competitive adsorption studies at 25 °C were conducted utilizing Micromeritics AutoChem 2910 atmospheric micro reactor. ... The analysis of the outlet gas stream was conducted utilizing a Pfeiffer Vacuum Thermostar <i>mass spectrometer</i>	2910
Adsorption of CO₂ on zeolites at moderate temperatures	RV Siriwardane, MS Shen, EP Fisher, J Losch - Energy Fuels, 2005	... temperature-programmed desorption (TPD) studies were conducted in a laboratory-scale fixed-bed reactor (Micromeritics model AutoChem 2910 atmospheric ... The outlet gas stream from the reactor was analyzed using a <i>mass spectrometer</i> (Pfeiffer Vacuum Thermostar). ...	2910
Adsorption of CO₂, N₂, and O₂ on Natural Zeoliteszeocat.es	RV Siriwardane, MS Shen, EP Fisher - Energy Fuels, 2003	... Competitive gas adsorption studies were conducted in a lab-scale fixed-bed reactor (Micromeritics AutoChem 2910 atmospheric microreactor) at 14.7 psi (1.01 × 10 ... The analysis of the outlet gas stream was conducted utilizing a Pfeiffer Vacuum Thermostar <i>mass spectrometer</i>	2910
Adsorption of volatile organic compounds onto carbon nanotubes, carbon nanofibers, and high-surface-area graphites	Diaz, E., Ordonez, S., Vega, A., Journal of Colloid And Interface Science, 305 (1), p.7-16, Jan 2007	...previous work[22]. Temperature-programmed desorption studies were carried out in a Micromeritics TPD- 2900 apparatus connected to a Glaslab 300 <i>mass spectrometer</i> . For this purpose, a 0.50-g carbon sample was heated from 50 to 950 °C at 10 °C...	2900

<p>Adsorptive removal of tetrahydrothiophene (THT) and tert-butylmercaptan (TBM) using Na-Y and AgNa-Y zeolites for fuel...</p>	<p>Lee, D., Ko, E.Y., Lee, H.C., Kim, S., Park, E.D., Applied Catalysis A, General, 334 (1), p.129-136, Jan 2008</p>	<p>...in a volumetric unit (ASAP2010, Micromeritics) after treating the samples in...monitoring the effluent using a <i>mass spectrometer</i> (QMS 200, Pfeiffer Vacuum) and AutoChem 2910 unit (Micromeritics) equipped with a thermal conductivity...</p>	<p>2910</p>
<p>AFeO₃ (A=La, Nd, Sm) and LaFe_{1-x}Mg_xO₃ perovskites as methane combustion and CO oxidation catalysts: structural,...</p>	<p>Ciambelli, P., Cimino, S., De Rossi, S., Lisi, L., Minelli, G., Porta, P., Russo, G., Applied Catalysis B: Environmental, 29 (4), p.239-250, Feb 2001</p>	<p>...Temperature programmed reduction (TPR) experiments were performed using a Micromeritics TPD/TPR 2900 analyzer equipped with a TC detector and coupled with a Hiden HPR 20 <i>mass spectrometer</i>. Samples (100 mg) were preheated in flowing air at 1073 K for 2...</p>	<p>2900</p>
<p>Al-and Ga-promoted WO₃/ZrO₂ strong solid acid catalysts and their catalytic ...</p>	<p>XR Chen, CL Chen, NP Xu, CY Mou - Catalysis Today, 2004</p>	<p>... NH₃ temperature-programmed desorption (NH₃-TPD) of samples was carried out on a Micromeritics AutoChem 2910 instrument. ... The desorption process was monitored by a Quadruple <i>Mass spectrometer</i> (Thermo ONIX, ProLab) connected on line through a heated capillary ...</p>	<p>2910</p>
<p>Alkylation of phenol with cyclohexanol and cyclohexene using HY and modified HY ...</p>	<p>R Anand, KU Gore, BS Rao - Catalysis Letters, 2002</p>	<p>... the temperature-programmed desorption method, with ammonia as a probe molecule (TPDA), using an Auto-Chem 2910 (Micromeritics, USA) instrument ... mm Å 0X25 "m). The GC-MS measurements were performed on a GCMS-QP2000A <i>mass spectrometer</i> equipped with ...</p>	<p>2910</p>
<p>Alumina supported, perovskite oxide based catalytic materials and their auto-exhaust application</p>	<p>Labhsetwar, N.K., Watanabe, A., Biniwale, R.B., Kumar, R., Mitsuhashi, T., Applied Catalysis B: Environmental, 33 (2), p.165-173, Sep 2001</p>	<p>...area, following the standard N-adsorption method, using Micromeritics ASAP-200 instrument. Slurry of perovskite powder was prepared...both thermal conductivity detector (TCD) and quadruple <i>mass spectrometer</i> (Q-Mass). The sample was pre-treated by heating at 800...</p>	
<p>AMnO₃ (A=La, Nd, Sm) and Sm_{1-x}Sr_xMnO₃ perovskites as combustion catalysts: structural, redox and catalytic...</p>	<p>Ciambelli, P., Cimino, S., De Rossi, S., Faticanti, M., Lisi, L., Minelli, G., Pettiti, I., (...), Turco, M., Applied Catalysis B: Environmental, 24 (3), p.243-253, Feb 2000</p>	<p>...2 were performed using a Micromeritics TPD/TPR 2900 analyser equipped with a...coupled with a Hiden HPR 20 <i>mass spectrometer</i>. The sample (30 mg) was...detected both by TCD and <i>mass spectrometer</i>. TPR profiles of NdMnO₃...</p>	<p>2900</p>
<p>Aromatics reduction of pyrolysis gasoline (PyGas) over HY-supported transition metal catalysts</p>	<p>Castano, P., Pawelec, B., Fierro, J.L.G., Arandes, J.M., Bilbao, J., Applied Catalysis A, General, 315, p.101-113, Nov 2006</p>	<p>...obtained using a Micromeritics Digisorb 2600 automatic...chemisorption in a Micromeritics ASAP 2010C apparatus...were conducted on a Micromeritics 2900 apparatus provided...recorded using a <i>mass spectrometer</i> quadrupole (Balzers...</p>	<p>2900</p>
<p>Assessment of dominant factors affecting liquid phase hydroisomerization on bifunctional zeolites</p>	<p>Funez, A., Thybaut, J.W., Marin, G.B., Sanchez, P., De Lucas, A., Valverde, J.L., Applied Catalysis A, General, 349 (1), p.29-39, Oct 2008</p>	<p>...were determined on a Micromeritics ASAP 2010 adsorptive...ammonia (TPDA) using a Micromeritics TPD/TPR 2900 analyzer. The sample...Micromeritics TPD/TPR 2900 analyzer. The experiments...SHIMADZU, coupled to a <i>mass spectrometer</i>, QP-5000 SHIMADZU...</p>	<p>2900</p>

BIOPROCESSING OF CRUDE OILS	6-Mar	...detector (FPD) and a Finnigan ion trap <i>mass spectrometer</i> (ITD) for simultaneous analyses...pyrolysis-gas chromatography- <i>mass spectrometer</i> (Py- GC-MS) utilized a Chemical...performed with a VG-induced- coupled- <i>mass spectrometer</i> (ICP-MS) .6. Saturate Aromatic...	
Brazilian Journal of Chemical Engineering - Influence of thermal treatments on the basic and catalytic properties of ... [55K]	R. Bastiani, I I. V. Zonno, I I. A. V. Santos, II C. A. Henriques, II, * J, May 2009	...adsorption-desorption at 77 K in a Micromeritics ASAP 2000. Before the analysis...for each sample were measured on a Micromeritics 2900 TPR/TPD analyzer with a quadrupole <i>mass spectrometer</i> detector. Prior to analysis, the...	2900
Breaking the dispersion-reducibility dependence in oxide-supported cobalt ...	A Martínez, G Prieto - Journal of Catalysis, 2007	... The reduction behavior of the supported oxidized cobalt phases was studied by hydrogen temperature-programmed reduction (H ₂ -TPR) in a Micromeritics AutoChem 2910 device. ... The desorbed hydrogen was monitored in a TCD coupled with a <i>mass spectrometer</i>	2910
Calcination temperature and CuO loading dependence on CuO-CeO ₂ catalyst activity for water-gas shift reaction	Djinovic, P., Batista, J., Pintar, A., Applied Catalysis A, General, 347 (1), p.23-33, Sep 2008	...were performed using a Micromeritics AutoChem II 2920 apparatus on...Pfeiffer vacuum ThermoStar <i>mass spectrometer</i> , connected to the Micromeritics AutoChem II 2920 apparatus...a TCD detector and <i>mass spectrometer</i> . 2.2.3 Catalytic activity...	2920
CaO-MgO CATALYSTS FOR SOOT COMBUSTION: KNO ₃ AS SOURCE FOR DOPING WITH POTASSIUM [118K]	Journal of the Chilean Chemical Society - 3/9/2010	...labeled O ₂ and secondary ion <i>mass spectrometer</i> (SIMS) showed the formation...conventional flow apparatus (Micromeritics Flowsorb 2130) by nitrogen...Thermostar GSD300T2 quadrupole <i>mass spectrometer</i> QMS200, connected on line...	
Carbon dioxide hydrogenation to methanol over the pre-reduced LaCrO ₃ . 5CuO. ...	L Jia, J Gao, W Fang, Q Li - Catalysis Communications, 2009	... H ₂ -temperature-programmed desorption (H ₂ -TPD) was conducted on Micromeritics AutoChem 2920 II instrument connected to a ThermoStar GSD 301 T2 <i>mass spectrometer</i> . About 100 mg of catalyst sample was used for each test. ...	2920
Carbon dioxide reforming of methane over La ₂ NiO ₄ as catalyst precursor— ...	G Sierra Gallego, F Mondragón, JM Tatibouët, J ... - Catalysis Today, 2008	... TPR and H ₂ chemisorption experiments were carried out in a Micromeritics AutoChem 2910 using about ... 2 was determined using 30% N ₂ /He as the adsorbate on a Micromeritics Flowsorb II ... 700 °C for 1 h. The reaction products were analyzed by an on-line <i>mass spectrometer</i>	2910
Carbon nanofibers grown on metallic filters as novel catalytic materialsepfl.ch	P Tribolet, L Kiwi-Minsker - Catalysis Today, 2005	... Temperature programmed oxidation (TPO) was carried out via an AutoChem 2910 instrument (Micromeritics SA, Belgium), connected to a <i>mass spectrometer</i> (Pfeiffer Vacuum) for on-line gas detection. The m/e ratios of 18 ...	2910
Carbon nanotube-supported gold nanoparticles as efficient catalysts for ...135.196.210.195	X Tan, W Deng, M Liu, Q Zhang, Y Wang - 135.196.210.195	... (Physical Electronics) using Al-K α radiation. NH ₃ -TPD measurements were performed using a Micromeritics AutoChem II 2920 instrument connected to a ThermoStar GSD 301 T2 <i>mass spectrometer</i> . (3) Catalytic reaction The ...	2920
Catalytic combustion of gasified biomass over Pt/Al ₂ O ₃	MFM Zwinkels, GM Eloise Heginuz, BH ... - Applied Catalysis A, ..., 1997	... The Pt dispersion of the fresh catalyst was determined by hydrogenoxygen titration using a Micromeritics TPD TPR 2900 temperatureprogrammed ... space velocity was 50,000 h ⁻¹ . All reaction products were analyzed online by a Balzers QMG 421 quadrupole <i>mass spectrometer</i>	2900

Catalytic combustion of hexane over transition metal modified zeolites NaX and CaA	Diaz, E., Ordonez, S., Vega, A., Coca, J., Applied Catalysis B: Environmental, 56 (4), p.313-322, Apr 2005	...adsorption at -196 °C with a Micromeritics ASAP 2000 surface analyser...experiments were carried out using a Micromeritics TPD- 2900 apparatus connected to a mass...using a Glaslab 300 quadrupole <i>mass spectrometer</i> , which used a capillary inlet...	2900
Catalytic combustion of methane on Pd-Cu/SiO₂ catalysts	Reyes, P., Figueroa, A., Pecchi, G., Fierro, J.L.G., Catalysis Today, 62 (2), p.209-217, Nov 2000	...nitrogen adsorption at 77 K in a Micromeritics Model Gemini 2370. Hydrogen...were carried out in a TPR/TPD 2900 Micromeritics system provided with a thermal-conductivity...some experiments a Quadrupole <i>Mass spectrometer</i> Hiden HPT 20 was used to detect...	2900
Catalytic combustion of methane over LaFeO₃ perovskites: the influence of ... [66K]	Journal of the Chilean Chemical Society - 6/9/2010	...BET equation on an automatic Micromeritics apparatus Model ASAP 2010...were performed in a TPR/TPD 2900 Micromeritics system with a thermal conductivity...experiments, a Quadrupole <i>Mass spectrometer</i> Hiden HPT 20 was used to detect...	2900
CATALYTIC COMBUSTION OF TOLUENE ON Pd-Cu/SiO₂ CATALYSTS	9-Jun	...nitrogen adsorption at 77 K in a Micromeritics Model Gemini 2370 and hydrogen...carried out in a TPR/TPD 2900 Micromeritics system provided with a thermal...some experiments a Quadrupole <i>Mass spectrometer</i> Hiden HAL 20 was used to detect...	2900
Catalytic Conversion of Ethylene to Propylene and Butenes over H-ZSM-5	B Lin, Q Zhang, Y Wang - Industrial & Engineering Chemistry Research	... desorption (NH ₃ -TPD) and O ₂ temperature programmed oxidation (O ₂ -TPO) measurements were performed on a Micromeritics AutoChem 2920 II ... a rate of 10 K min ⁻¹ , and the desorbed NH ₃ molecules were detected by ThermoStar GSD 301 T2 <i>mass spectrometer</i> with a ...	2920
Catalytic decomposition of N₂O and catalytic reduction of N₂O and N₂O+ NO by ...	A Guzmán-Vargas, G Delahay, B Coq - Applied Catalysis B, ..., 2003	... TPR by H ₂ was carried out with a Micromeritics AutoChem 2910 apparatus using TCD detection ... The effluent composition was monitored continuously by sampling on line to a quadrupole <i>mass spectrometer</i> (Pfeiffer Omnistar) equipped with Channeltron and Faraday detectors (0 ...	2910
Catalytic decomposition of N₂O on supported Pd catalysts: Support and thermal ageing effects on the catalytic...	Dacquin, J.P., Dujardin, C., Granger, P., Catalysis Today, 137 (2), p.390-396, Sep 2008	... Temperature-programmed reduction experiments (TPR) were performed in a Micromeritics AutoChem II 2920 apparatus (5 Vol.% H ₂ /Ar, 10 °C/min ... conductivity detectors for the quantification of NO, O ₂ , N ₂ O and N ₂ and a Balzer quadrupole <i>mass spectrometer</i> which allowed ...	2920
Catalytic deoxygenation of unsaturated renewable feedstocks for production of ...	M Snáre, I Kubičková, P Mäki-Arvela, D Chichova, K ... - Fuel, 2008	... Temperature programmed desorption of hydrogen on the palladium catalyst was performed with the Micromeritics AutoChem 2910 coupled to GC-MS (Balzers Instruments, Omnistar). ... Product identification was validated with a gas chromatograph - <i>mass spectrometer</i> (GC-MS). ...	2910
Catalytic Hydrodechlorination of Tetrachloroethylene over Pd/TiO₂ Minimonoliths	CA González, CM de Correa - 2009	... Temperature-programmed oxidation (TPO) in flowing 5% O ₂ /Ar was carried out in a Micromeritics AutoChem II 2920 instrument equipped with a thermal conductivity detector (TCD) coupled to a quadrupole <i>mass spectrometer</i> (Pfeiffer Vacuum Omnistar) following the evolution ...	2920
Catalytic monoliths for ethanol steam reforming	A Casanovas, C de Leitenburg, A Trovarelli, J Llorca - Catalysis Today, 2008	... Temperature programmed reduction (TPR) was carried out with a Micromeritics AutoChem II 2920 instrument using a H ₂ /Ar mixture (5% H ₂) at 10 K min ⁻¹ and a TCD detector. 2.3. ... The effluent of the reactor was monitored on line with a MKS Cirrus <i>mass spectrometer</i>	2920

Catalytic partial oxidation of a diesel surrogate fuel using an Ru-substituted ...	DJ Haynes, A Campos, DA Berry, D Shekhawat, A Roy, ... - Catalysis Today, 2009	... Temperature programmed reduction (TPR) and H ₂ pulse chemisorption experiments were performed in a Micromeritics AutoChem 2910 unit. ... The dry gas products: H ₂ , CO, CO ₂ , and N ₂ were analyzed continuously by an online Thermo Onix <i>mass spectrometer</i> (Model no. ...	2910
Catalytic partial oxidation of n-tetradecane using pyrochlores: Effect of Rh and Sr substitution	Haynes, D.J., Berry, D.A., Shekhawat, D., Spivey, J.J., Catalysis Today, 136 (3), p.206-213, Jul 2008	...chemisorption analyses were conducted with a Micromeritics AutoChem 2910 unit. Before the start of the TPR, the catalyst...continuously by means of an online Thermo Onix <i>mass spectrometer</i> (Model no. Prima deltab, a 200a.m.u. scanning...	2910
Catalytic Post-Treatment of Automotive Exhaust Gas from Natural Gas Combustion ...	Y Renème, F Dhainaut, P Granger - Topics in Catalysis	... in air at 400 °C during 8 h. H ₂ -temperature-programmed reduction experiments (H ₂ -TPR) were performed in a Micromeritics AutoChem II 2920 ... 150 mg with a total flow rate of 30 mL min ⁻¹ . Reactants and products were analysed using a Balzers QMG 200 <i>mass spectrometer</i>	2920
Catalytic purification of waste gases containing VOC mixtures with Ce/Zr solid solutions	Jl Gutiérrez-Ortiz, B de Rivas, R López-Fonseca ... - Applied Catalysis B, ..., 2006	... Temperature-programmed desorption (TPD) of various probe molecules (NH ₃ , H ₂ O and CO ₂) was performed on a Micromeritics AutoChem 2910 instrument equipped with a thermal conductivity detector (TCD). Prior to adsorption ...	2910
Catalytic reduction of SO ₂ with CO over supported iron catalysts dicp.ac.cn	X Wang, A Wang, N Li, X Wang, Z Liu, T Zhang - Ind. Eng. Chem. Res, 2006	... NH ₃ -TPD of the three acidic supports (HZSM-5, γ-Al ₂ O ₃ , and SiO ₂) and CO ₂ -TPD of the MgO support were measured with the Micromeritics AutoChem II 2920 Automated Catalyst ... The CO-TPR spectra were recorded with a <i>mass spectrometer</i> as a detector. 2.5. ...	2920
Ce-Zr-Sr mixed oxide prepared by the reversed microemulsion method for improved Pd-only three-way catalysts	Wang, J., Shen, M., An, Y., Wang, J., Catalysis Communications, 10 (1), p.103-107, Oct 2008	...H ₂ -TPR experiments were carried out using a Micromeritics AutoChem 2910 . The catalyst was first purged under N ₂ ...Ar and He were monitored on-line by quadrupole <i>mass spectrometer</i> (Balzers, QMS200). The pulse frequencies were...	2910
Changing the Oxygen Mobility in Co/Ceria Catalysts by Ca Incorporation: Implications for Ethanol Steam Reforming	Hua Song and Umit S. Ozkan* J. Phys. Chem. A, October 9, 2009	... O ₂ pulse chemisorption experiments were conducted using AutoChem II 2920 (Micromeritics) connected to a Cirrus <i>Mass Spectrometer</i> (MKS ...	2920
Characterisation of the deactivation of platinum and palladium supported on activated carbon used as...	Ordóñez, S., Dez, F.V., Sastre, H., Applied Catalysis B: Environmental, 31 (2), p.113-122, May 2001	...Nitrogen porosimetry measurements were performed in a Micromeritics ASAP 2000 apparatus. Morphology and size distribution...and reduction (TPR) studies were carried out in a Micromeritics TPD- 2900 apparatus, equipped with TCD detector, and connected...	2900
Characteristics of Fe-exchanged natural zeolites for the decomposition of N ₂ O and its selective catalytic reduction...	Ates, A., Applied Catalysis B, Environmental, 76 (3), p.282-290, Nov 2007	...adsorption-desorption (ASAP 2000, Micromeritics) at 77K. Prior...performed with an AutoChem 2910, Micromeritics . In TPD-NH ₃ , the...characterisation (AutoChem 2910, Micromeritics ...using a quadrupole <i>mass spectrometer</i> (QMS 422 Pfeiffer...	2910
Characterization and catalytic performance of vanadium supported on sulfated Ti- ...	J Arfaoui, L Khalfallah Boudali, A Ghorbel, G ... - Journal of Materials by temperature-programed desorption (TPD) of ammonia using an AUTOCHEM 2910 (Micromeritics) Temperature programmed reduction have been carried out in the AUTOCHEM 2910 with ... analyzed by sampling on line with a quadrupole <i>mass spectrometer</i> (Pfeiffer Omnistar ...	2910

Characterization And Study Of Catalytic Activity Of Cu/Zno/Al2o3 Systems	M Turco, G Bagnasco, C Cammarano, U Costantino, M ... - nt.ntnu.no	... TPR measurements were carried out on samples treated in air flow at 450°C using a 5% H2/Ar mixture and a heating rate of 10°C min-1 on a Micromeritics 2900 apparatus. ... A <i>mass spectrometer</i> Hiden was employed for identification of products not detected by GC. ...	2900
Characterization of Acid Sites Using Temperature-Programmed Desorptionmicromeritics.com	TP Desorption - micromeritics.com	... use of organic amines and other basic vapors is possible using Micromeritics' AutoChem Series of ... The temperature zones for the AutoChem should be altered to reflect the use of ... For the reactive probes (propyl amines), a <i>mass spectrometer</i> is required to quantify the density of ...	AutoChem
Characterization of carbon nanofiber composites synthesized by shaping process	P Li, TJ Zhao, JH Zhou, ZJ Sui, YC Dai, WK Yuan - Carbon, 2005	... The TPD profiles were examined on a Micromeritics AutoChem II apparatus ... rate of the furnace (10 °C/min) were controlled and the amounts of CO and CO 2 desorbed from the carbon materials (about 0.25 g) were monitored with an ABB Questor GP process <i>mass spectrometer</i>	2920
Characterization of coke deposited on Pt/alumina catalyst during reforming of liquid hydrocarbons	Shamsi, A., Baltrus, J.P., Spivey, J.J. , Applied Catalysis A, General, 293, p.145-152, Sep 2005	...were measured. A Micromeritics Pulse Chemisorb...carried out by using a Micromeritics AutoChem II instrument. The...the Micromeritics AutoChem instrument. 2.2...by a quadrupole <i>mass spectrometer</i> using internal and...	2920
Characterization of precursors and reactivity of LaNi1- xCoxO3 for the partial ...	GC de Araujo, S Lima, MC Rangel, VL Parola, MA ... - Catalysis Today, 2005	... 2000 apparatus. Prior to the adsorption experiments, the samples were outgassed at 423 K for 2 h. Temperature-programmed reduction profiles were taken with a Micromeritics TPD/TPR 2900 apparatus. The sample (ca. 30 ...	2900
Characterization of surface oxygen complexes on carbon nanofibers by TPD, XPS ...	JH Zhou, ZJ Sui, J Zhu, P Li, D Chen, YC Dai, WK Yuan - Carbon, 2007	... designations. 2.2. TPD. The TPD experiments were carried out on AutoChem II 2920 (Micromeritics, USA) . A ... min. The downstream gas was diverted to a quadrupole <i>mass spectrometer</i> (Questor, ABB Extrel, USA) for analysis. ...	2920
Characterizations of Unsupported and Supported Rhodium- Iron Phosphate ...	Y Wang, Q Yuan, Q Zhang, W Deng - 2007	... Characterization Method. Temperature-programmed reduction with CO (CO TPR) was performed on an AutoChem 2920 II instrument (Micromeritics Instrument Co.) connected to a ThermoStar <i>mass spectrometer</i> (Pfeiffer Vacuum). ...	2920
Co 3 O 4/CoAl 2 O 4 를 이용한 화학적 순환 연소	정진혁, 박종원, 주윤경, 박종수, 정현, 이호태, 윤 ... - cheric.org	... 본 실험에서 사용한 반응장치는 제조된 금속산화물 매체의 기초 산화 환원 활성을 분석하기 위해 U-type 미분 반응기(Micromeritics Co. AutoChem 온도는 20°C/min의 승온 속도로 50°C에서 1000°C까지 온도 조건하에서 반응 실험을 실시하여 TCD와 <i>mass spectrometer</i> 로 분석하였다. ...	AutoChem
CO oxidation and methane combustion on LaAl1-xFexO3 perovskite solid ...	P Ciambelli, S Cimino, G Lasorella, L Lisi, S De ... - Applied Catalysis B, ..., 2002	... Temperature programmed reduction (TPR) experiments were performed using a Micromeritics TPD/TPR 2900 analyser equipped with a TC detector and coupled with a Hiden HPR 20 <i>mass spectrometer</i> . Samples (0.1 g) were ...	2900

CO2 reforming of CH4 over La–Ni based perovskite precursors	GS Gallego, F Mondragón, J Barrault, JM ... - Applied Catalysis A, ..., 2006	... TPR and H ₂ chemisorption experiments were carried out in a Micromeritics AutoChem 2910 using about ... 2 was measured using 30% N ₂ /Ar as the adsorbate on a Micromeritics Flowsorb II ... at 700 °C for 1 h. The reaction products were analyzed by an online <i>mass spectrometer</i>	2910
Cobalt and Copper Composite Oxides as Efficient Catalysts for Preferential ...	D Li, X Liu, Q Zhang, Y Wang, H Wan - Catalysis Letters, 2009	... lysts were studied by temperature-programmed reduction techniquesincluding H ₂ -TPR and CO-TPR with a Micromeritics Auto Chem 2920 II ... detector (TCD), and the amount of CO consumption was measured using a Pfeiffer Vacuum ThermoStar <i>mass spectrometer</i> with a ...	2920
Cobalt supported on morphologically tailored SBA-15 mesostructures: The impact of pore length on metal dispersion and...	Prieto, G., Martinez, A., Murciano, R., Arribas, M.A. , Applied Catalysis A, General, 367 (1), p.146-156, Oct 2009	...were recorded in a Micromeritics ASAP 2000 device...H ₂ -TPR) in a Micromeritics AutoChem 2910 device. The...downstream and a <i>Mass spectrometer</i> on-line registered...in an ASAP 2010C Micromeritics equipment by extrapolating...	2910
Combustion of trichloroethylene and dichloromethane over protonic zeolites: Influence of adsorption properties on the...	Intriago, L., Diaz, E., Ordonez, S., Vega, A. , Microporous and Mesoporous Materials, 91 (1), p.161-169, Apr 2006	...adsorption at -196°C with a Micromeritics ASAP 2000 surface analyser...studies were carried out using a Micromeritics TPD- 2900 apparatus connected to a mass...using a Glaslab 300 quadrupole <i>mass spectrometer</i> , which used a capillary inlet...	2900
Compact string reactor for autothermal hydrogen production	C Horny, A Renken, L Kiwi-Minsker - Catalysis Today, 2007	... Temperature-programmed reduction (TPR) and oxidation (TPO) were carried out in a Micromeritics AutoChem 2910 apparatus by passing, respectively ... The outlet concentrations were monitored by a <i>mass spectrometer</i> (Thermostar 200, Pfeiffer Vacuum) to obtain TPO and TPR ...	2910
Comparative study of CuO-CeO₂ catalysts prepared by wet impregnation and deposition-precipitation	Gurbani, A., Ayastuy, J.L., Gonzalez-Marcos, M.P., Herrero, J.E., Guil, J.M., Gutierrez-Ortiz, M.A. , International Journal of Hydrogen Energy, 34 (1), p.547-553, Jan 2009	...N ₂ adsorption-desorption isotherms at 78K (Micromeritics ASAP 2010). The crystalline...CO-TPR was followed by a <i>mass spectrometer</i> (MS) (MKS Cirrus 300) coupled...same experimental equipment (Micromeritics AutoChem 2910) with about 0.4g of...	2910
Comparative study of CuO–CeO₂ catalysts prepared by wet impregnation and ...	A Gurbani, JL Ayastuy, MP González-Marcos, ... - International Journal of ..., 2009	... was continuously monitored by TCD detector; CO consumption in CO-TPR was followed by a <i>mass spectrometer</i> (MS) (MKS ... TPR, TPD and OSC measurements were conducted in the same experimental equipment (Micromeritics AutoChem 2910) with about 0.4 g of sample ...	2910
Comparison of adsorption properties of a chemically activated and a steam-activated carbon, using inverse gas...	Di@?az, E., Ordonez, S., Vega, A., Coca, J. , Microporous and Mesoporous Materials, 82 (1), p.173-181, Jul 2005	...by nitrogen adsorption at -196°C (Micromeritics ASAP 2000 surface analyser), assuming...desorption studies were carried out in a Micromeritics TPD- 2900 apparatus connected to a Glaslab 300 <i>mass spectrometer</i> . For this purpose, 0.50g activated...	2900
Comparison of the promoting effects of gallium and aluminium on the n-butane ...	CJ Cao, XZ Yu, CL Chen, NP Xu, YR ... - Reaction Kinetics and ..., 2004	... NH ₃ -TPD and H ₂ -TPR were carried out using a Micromeritics AutoChem 2910 instrument. A 0.1 g sample was used for each TPD or TPR experiment. ... The NH ₃ -TPD and H ₂ -TPR processes were monitored with a Quadruple <i>Mass spectrometer</i> (Thermo ONIX, ProLab). ...	2910

<p>Comparison of water-gas shift reaction activity and long-term stability of nanostructured CuO-CeO₂ catalysts prepared...</p>	<p>Djinovic, P., Batista, J., Levec, J., Pintar, A., Applied Catalysis A, General, 364 (1), p.156-165, Jul 2009</p>	<p>...measurements were performed using a Micromeritics ASAP 2020 MP/C apparatus...measurements were performed on a Micromeritics AutoChem II 2920 catalyst characterization...identified and quantified using a <i>mass spectrometer</i> (Pfeiffer Vacuum, model Thermostar...</p>	<p>2920</p>
<p>Comparison of water-gas shift reaction activity and long-term stability of ...</p>	<p>P Djinović, J Batista, J Levec, A Pintar - Applied Catalysis A, General, 2009</p>	<p>... H₂-TPR/TPD measurements were performed on a Micromeritics AutoChem II 2920 catalyst characterization system, using 250 mg of a sample. ... The desorbed gasses were identified and quantified using a <i>mass spectrometer</i> (Pfeiffer Vacuum, model Thermostar). 2.5. ...</p>	<p>2920</p>
<p>Condensation of glyceraldehyde acetonide and acetone over basic catalysts</p>	<p>Veloso, C.O., Henriques, C.A., Dias, A.G., Monteiro, J.L.F., Catalysis Today, 107, p.294-301, Oct 2005</p>	<p>...N₂adsorption-desorption at 77K in a Micromeritics ASAP 2000. Before the analysis, the...desorption profile were measured on a Micromeritics 2900 TPR/TPD analyzer with a quadrupole <i>mass spectrometer</i> detector (Balzers QMS-200). 2.4 Reaction...</p>	<p>2900</p>
<p>Condensation of glyceraldehyde acetonide with ethyl acetoacetate over Mg, Al- ...</p>	<p>CO Veloso, CN Pérez, BM de Souza, EC Lima, ... - Microporous and ..., 2008</p>	<p>... TPD analyses were run under He at a heating rate of 20 °C min⁻¹ up to 450 °C. The amount of CO₂ chemisorbed and its desorption profile were measured on a Micromeritics 2900 TPR/TPD analyzer with a quadrupole <i>mass spectrometer</i> detector (Balzers QMS-200). 2.4. ...</p>	<p>2900</p>
<p>Conversion of Cellulose into Sorbitol over Carbon Nanotube-Supported ...</p>	<p>W Deng, X Tan, W Fang, Q Zhang, Y Wang - Catalysis Letters</p>	<p>... NH₃ temperature-programmed desorption (NH₃-TPD) and H₂ temperature-programmed desorption (H₂-TPD) were performed on a Micromeritics AutoChem 2920 II ... rate of 10 °C min⁻¹. The desorbed NH₃ were monitored by ThermoStar GSD 301 T2 <i>mass spectrometer</i> with ...</p>	<p>2920</p>
<p>Copper-based efficient catalysts for propylene epoxidation by molecular oxygen</p>	<p>Y Wang, H Chu, W Zhu, Q Zhang - Catalysis Today, 2008</p>	<p>... H₂-TPR and NH₃-TPD were performed using a Micromeritics AutoChem II 2920 instrument. ... TPD was performed in He flow by raising the temperature to 973 K at a rate of 10 K min⁻¹. The desorbed NH₃ was detected with a <i>mass spectrometer</i> (ThermoStar GSD 301 T2) by ...</p>	<p>2920</p>
<p>Cu/γ-Al₂O₃ catalyst for the combustion of methane in a fluidized bed reactor</p>	<p>Iamarino, M., Chirone, R., Lisi, L., Pirone, R., Salatino, P., Russo, G., Catalysis Today, 75 (1), p.317-324, Jul 2002</p>	<p>...Temperature programmed reduction (TPR) experiments were performed using a Micromeritics TPD/TPR 2900 analyser equipped with a TC detector and coupled with a Hiden HPR 20 <i>mass spectrometer</i>. Catalyst (100 mg) was preheated in air at 600 °C for 2 h and, after...</p>	<p>2900</p>
<p>Cu/ZnO/Al₂O₃ catalysts for oxidative steam reforming of methanol: The role of Cu ...</p>	<p>M Turco, G Bagnasco, C Cammarano, P ... - Applied Catalysis B, ..., 2007</p>	<p>... N₂O passivation method that involves the formation of surface Cu₂O and subsequent H₂ reduction [47], using the same Micromeritics 2900 apparatus. ... allowed analysis of H₂, CO (detection limit = 0.01%), CO₂, O₂, CH₄, CH₃OH, H₂O. A <i>mass spectrometer</i> Hiden was ...</p>	<p>2900</p>
<p>Cu/γ-Al₂O₃ catalyst for the combustion of methane in a fluidized bed reactor</p>	<p>M Iamarino, R Chirone, L Lisi, R Pirone, P Salatino, G ... - Catalysis Today, 2002</p>	<p>... analysis. Temperature programmed reduction (TPR) experiments were performed using a Micromeritics TPD/TPR 2900 analyser equipped with a TC detector and coupled with a Hiden HPR 20 <i>mass spectrometer</i>. Catalyst (100 ...</p>	<p>2900</p>

Deactivation due to sulfur poisoning and carbon deposition on Rh-Ni/Al ₂ O ₃ catalyst during steam reforming of...	SL Lakhapatri, MA Abraham - Applied Catalysis A, General, 2009	... Temperature programmed oxidation (TPO) and reduction (TPR) studies were done using a Micromeritics AutoChem 2910 equipped with a thermal conductivity ... using 3% O ₂ . For TPO of the used catalyst, the instrument was coupled with a <i>mass spectrometer</i> to measure the ...	2910
Deactivation Kinetics for Direct Dimethyl Ether Synthesis on a CuO- ZnO- Al ₂ O ₃ /γ- ...	I Sierra, J Ereña, AT Aguayo, M Olazar, J Bilbao - 2009	... The metal surface is 11.7 m ² (g of catalyst) ⁻¹ and has been determined by N ₂ O chemisorption (Micromeritics AUTOCHEM 2920 online with a Balzers Instruments Omnistar <i>mass spectrometer</i>). The physical properties ...	2920
Deactivation of a CuO- ZnO- Al ₂ O ₃ /[gamma]- Al ₂ O ₃ Catalyst in the Synthesis of ...	J Erena, I Sierra, M Olazar, AG Gayubo, AT ... - Ind. Eng. Chem. ..., 2008	... desorption, temperature is increased from 150 to 550 °C, at a rate of 5 °C min ⁻¹ . Copper surface areas (S _{Cu}) for the fresh and deactivated catalysts have been determined by N ₂ O chemisorptions in a Micromeritics AutoChem II 2910 coupled to the <i>mass spectrometer</i>	2910
Deactivation of a Pd/Al ₂ O ₃ catalyst used in hydrodechlorination reactions: Influence of the nature of...	Lopez, E., Ordonez, S., Diez, F.V., Applied Catalysis B, Environmental, 62 (1), p.57-65, Jan 2006	...measurements were performed in a Micromeritics ASAP 2000 apparatus. Crystallographic...studies were carried out in a Micromeritics TPD- 2900 apparatus, equipped with TCD...CO in the outlet gas with a <i>mass spectrometer</i> . The results for the CO ₂ signal...	2900
Deactivation of Au/CeOx water gas shift catalysts	CH Kim, LT Thompson - Journal of Catalysis, 2005	... Temperature-programmed oxidation (TPO) and CO chemisorption were performed with a Micromeritics AutoChem 2910 equipped with a Thermo Onix <i>mass spectrometer</i> . The samples were degassed in He at 200 °C prior to analysis. ...	2910
Deactivation of real three way catalysts by CePO ₄ formationuam.es	C Larese, FC Galisteo, ML Granados, R ... - Applied Catalysis B, ..., 2003	... monochromator. TPR profiles were recorded in a Micromeritics TPD/TPR 2900 equipment. ... HORIBA VIA-510), O ₂ by paramagnetic detector (mod. HORIBA MPA-510) and C ₃ H ₆ , H ₂ and H ₂ O by a quadrupole <i>mass spectrometer</i> (mod. BALTZER ...	2900
Decarboxylation of fatty acids over Pd supported on mesoporous carbon	I Simakova, O Simakova, P Mäki-Arvela, DY Murzin - Catalysis Today, 2009	... CO pulse chemisorption was performed using AutoChem 2910 apparatus (Micromeritics). Prior to the measurements the catalysts were reduced similarly as prior to the reaction (see below). ... The products were identified with a gas chromatograph- <i>mass spectrometer</i> (GC-MS). ...	2910
Dehydrogenation of long chain paraffins over supported Pt-Sn-K/Al ₂ O ₃ catalysts: A study of the alumina support effect	He, S., Sun, C., Bai, Z., Dai, X., Wang, B., Applied Catalysis A, General, 356 (1), p.88-98, Mar 2009	...adsorption system (Micromeritics ASAP 2010, American...catalysts (Micromeritics AutoChem II 2920 , American...using a Micromeritics AutoChem II 2920 apparatus...in the Micromeritics AutoChem II 2920 apparatus...detected by a quadruple <i>mass spectrometer</i> (Balzers OmniStar 300...	2920
Deoxygenation of palmitic and stearic acid over supported Pd catalysts: Effect of ...	I Simakova, O Simakova, P Mäki-Arvela, A ... - Applied Catalysis A, ..., 2009	... The product identification was validated with a gas chromatograph- <i>mass spectrometer</i> (GC-MS). 2.3. Catalyst preparation and characterization. ... Metal dispersion was measured also by CO chemisorption using AutoChem 2910 apparatus (Micromeritics). ...	2910
Department of Chemical Engineering wvu.edu	CH Clark - 2005 - eidr.wvu.edu	... Page 18. 10 require either a TPR apparatus attached to a <i>mass spectrometer</i> or a way of modeling the underlying peak structure (2,3). The characterization methods discussed thus far can be used to characterize the bulk of the material. ...	

Department of Chemical Engineeringwvu.edu	CH Clark - 2005 - eidr.wvu.edu	... Page 18. 10 require either a TPR apparatus attached to a <i>mass spectrometer</i> or a way of modeling the underlying peak structure (2,3). The characterization methods discussed thus far can be used to characterize the bulk of the material. ...	
Development of an industrial characterisation method for naphtha reforming ...	MP Gonzalez-Marcos, B Inarra, JM Guil, MA Gutierrez-... - Catalysis Today, 2005	... Acidity of the catalysts was evaluated by TPD of ammonia and was carried out in a Micromeritics AutoChem 2910 instrument. ... The detectors were: an AED, used for quantification, and a <i>mass spectrometer</i> , for identification of the compounds. ...	2910
DEVELOPMENT OF ON-LINE GC/MS MONITORING TECHNIQUES FOR HIGH PRESSURE FUEL CONVERSION PROCESSES	6-Mar	...directly coupled to a modified Ion Trap <i>Mass spectrometer</i> (ITMS, Finnigan MAT) with tandem...15 C h i n Miniaturized Ion Trap <i>Mass spectrometer</i> (Finnigan-MAT) with a PC comouter...cap. 40 C isothermal quadrupole <i>mass spectrometer</i> - modcl HP 5971 (Hewlett- Packard...	
doi:10.1016/S0926-3373(02)00161-3	5-Aug	...monochromator. TPR profiles were recorded in a Micromeritics TPD/TPR 2900 equipment. The 100 mg of powder sieved...510) and C ₃ H ₆ , H ₂ and H ₂ O by a quadrupole <i>mass spectrometer</i> (mod. BALTZER Prisma QMS 200 controlled by BALTZER QuadstarTM...	2900
Dry reforming of methane over LaNi _{1-y} ByO _{3±δ} (B= Mg, Co) perovskites used as ...	GS Gallego, C Batiot-Dupeyrat, J Barrault, E ... - Applied Catalysis A, ..., 2007	... TPR experiments were carried out in a Micromeritics AutoChem 2910 equipment using about 160 mg of ... The nitrogen gas adsorption were performed on a Micromeritics ASAP 2000 apparatus at -196 °C. ... The reaction products were analyzed by an on-line <i>mass spectrometer</i>	2910
Dry reforming of methane over LaNi _{1-y} ByO _{3±δ} (B=Mg, Co) perovskites used as catalyst precursor	Gallego, G.S., Batiot-Dupeyrat, C., Barrault, J., Florez, E., Mondragon, F., Applied Catalysis A, General, 334 (1), p.251-258, Jan 2008	...experiments were carried out in a Micromeritics AutoChem 2910 equipment using about...adsorption were performed on a Micromeritics ASAP 2000 apparatus at -196...were analyzed by an on-line <i>mass spectrometer</i> . 3 Results and discussion...	2910
Dry reforming of methane over nickel catalysts supported on the cuspidine-like ...	V Garcia, MT Caldes, O Joubert, GS Gallego, C Batiot- ... - Catalysis Today, 2008	... The temperature-programmed reduction (TPR) studies were performed in a chemisorption unit Micromeritics AutoChem 2910 with samples of 50 mg. ... The composition of the reactants/products mixture was analysed with an on-line <i>mass spectrometer</i>	2910
Dynamic oxygen storage and release over Cu _{0.1} Ce _{0.9} O _x and Cu _{0.1} Ce _{0.6} Zr _{0.3} O _x complex compounds and...	Jia, L., Shen, M., Wang, J., Gu, W., Journal of Alloys and Compounds, 473 (1), p.293-297, Apr 2009	...monitored with on-line process by quadrupole <i>mass spectrometer</i> (Balzers, QMS200). In this experiment, isothermal...reduction (TPR) experiments were performed in an AutoChem 2910 Micromeritics instrument, equipped with a thermal conductivity...	2910
Dynamics of N ₂ O decomposition over HZSM-5 with low Fe contentepfl.ch	DA Bulushev, L Kiwi-Minsker, A Renken - Journal of Catalysis, 2004	... Catalytic activity measurements. Catalytic activity was measured in a Micromeritics AutoChem 2910 analyzer. A ThermoStar 200 (Pfeiffer Vacuum) quadrupole <i>mass spectrometer</i> was used to analyze the gas phase composition. ...	2910
Effect of activated carbon on the dispersion of Ru and K over supported Ru-based catalyst for ammonia synthesis	Han, W., Liu, H., Zhu, H., Catalysis Communications, 8 (3), p.351-354, Mar 2007	...N ₂ physisorption was carried on Micromeritics ASAP2010. TPD-MS...was performed on Micromeritics AutoChem 2910 attaching with...conductivity detector and <i>mass spectrometer</i> detector. Ru and...on Micromeritics AutoChem 2910 . The active...	2910

Effect of carbon addition on the Pt-Sn/ γ -Al ₂ O ₃ catalyst for long chain paraffin dehydrogenation to olefin	He, S., Sun, C., Du, H., Dai, X., Wang, B., Chemical Engineering Journal, 141 (1), p.284-289, Jul 2008	...adsorption system (Micromeritics ASAP 2010, American...mercury porosimeter (Micromeritics Autopore 9520, American...catalysts (Micromeritics AutoChem II 2920 , American...catalysts (Micromeritics AutoChem II 2920 , American...detected by a quadruple <i>mass spectrometer</i> . 2.3 Dehydrogenation...	2920
Effect of carbon addition on the Pt-Sn/ γ -Al ₂ O ₃ catalyst for long chain paraffin ...dicp.ac.cn	S He, C Sun, H Du, X Dai, B Wang - Chemical Engineering Journal, 2008	... desorption of ammonia (NH ₃ -TPD) experiments were carried out to analyze the acidic properties of the catalysts (Micromeritics AutoChem II 2920 ... out with a temperature ramp of 10 °C min ⁻¹ , and the desorbed products were detected by a quadruple <i>mass spectrometer</i> . 2.3. ...	2920
Effect of carbon nanofiber functionalization on the adsorption properties of volatile organic compounds	Cuervo, M.R., Asedegbega-Nieto, E., Diaz, E., Vega, A., Ordonez, S., Castillejos-Lopez, E., Rodriguez-Ramos, I., Journal of Chromatography A, 1188 (2), p.264-273, Apr 2008	...at -196°C with a Micromeritics ASAP 2000 surface...TPO), employing a Micromeritics TPD- 2900 apparatus connected...Pfeiffer Vacuum-300 <i>mass spectrometer</i> (Nashua, NH, USA...with a quadrupole <i>mass spectrometer</i> (Balzers QMG 421-C...	2900
EFFECT OF CHLORINE PRECURSOR IN SURFACE AND CATALYTIC PROPERTIES OF Fe/TiO ₂ ...	9-Jun	...recorded with an automatic Micromeritics system ASAP 2001, using nitrogen...carried out in a TPR/TPD 2900 Micromeritics system provided with a thermal...some experiments a quadrupole <i>mass spectrometer</i> Hiden HPT 20 was used to detect...	2900
Effect of Co Content Upon the Bulk Structure of Sr-and Co-doped LaFeO ₃	JN Kuhn, US Ozkan - Catalysis Letters, 2008	... area measurements were made by the physical adsorption of Kr at 77 K on a Micromeritics ASAP 2010. ... were conducted on both a Thermo-Finnigan Trace Ultra differential scanning quadrupole (DSQ) gas chromatograph/ <i>mass spectrometer</i> (GC/MS) and Auto- chem II 2920 ...	2920
Effect of copper loading on copper-ceria catalysts performance in CO selective oxidation for fuel cell applications	Ayastuy, J.L., Gurbani, A., Gonzalez-Marcos, M.P., Gutierrez-Ortiz, M.A., International Journal of Hydrogen Energy, 35 (3), p.1232-1244, Feb 2010	...desorption isotherms at 78K (Micromeritics ASAP 2010). Ultraviolet...CO-TPR was followed by a <i>mass spectrometer</i> (MS) (MKS Cirrus 300...experimental equipment (Micromeritics AutoChem 2910) with ca. 0.4g of...	2910
Effect of Dimethyl Ether Co-feed on Catalytic Performance of Methane ...dicp.ac.cn	H Chen, Y Li, W Shen, Y Xu, X Bao - Journal of Natural Gas ..., 2004 - fruit.dicp.ac.cn	... TGA profile was recorded automatically. TPO was conducted on a Micromeritics AutoChem II2920 instrument equipped with a thermal conductivity detector (TCD) and a <i>mass spectrometer</i> (MS). 0.03 g coked catalyst packed ...	2920
Effect of H ₂ O and SO ₂ on the activity of Pd/TiO ₂ catalysts in catalytic reduction of NO with methane in the presence...	Mitome, J., Karakas, G., Bryan, K.A., Ozkan, U.S., Catalysis Today, 42 (1), p.3-11, Jun 1998	...the catalysts used were measured by a Micromeritics 21() E Accusorb instrument using nitrogen...oxygen concentrations between 0 and 2900 ppm at 500C. At 2 concentration of 3800...CO and between N ₂ O and CO ₂ using the <i>mass spectrometer</i> . The reaction was first brought to steady...	2900
Effect of hydrothermal treatment on the composition and structure of Pt (IV) hydroxo ...	OB Bel'skaya, VA Drozdov, TI Gulyaeva, AB ... - Kinetics and ..., 2009	... and thermal decomposition products were analyzed on an STA 449 C Jupiter thermal analyzer (Netzsch) connected to a QMS 403 C Aeolos quadrupole <i>mass spectrometer</i> with a ... Before measurements with an AutoChem 2920 instrument (Micromeritics), the sample was ...	2920

Effect of La ₂ O ₃ doping on syntheses of C ₁ –C ₁₈ mixed linear α-alcohols from ...	G Jiao, Y Ding, H Zhu, X Li, J Li, R Lin, W Dong, ... - Applied Catalysis A, ..., 2009	... TPR experiments were performed on a Micromeritics AutoChem 2910 apparatus ... The hydrogen consumption was recorded with a thermal conductivity detector (TCD) while some effluent was simultaneously traced with an Omnistar 300 quadrupole <i>mass spectrometer</i> for analysis ...	2910
Effect of MgO addition on the basicity of Ni/ZrO ₂ and on its catalytic activity in carbon dioxide reforming of methane	V García, JJ Fernández, W Ruíz, F Mondragón, A ... - Catalysis ..., 2009	... NiO x /ZrO ₂ –MgO) was studied by temperature-programmed reduction (TPR) in a chemisorption unit (AutoChem 2910, Micromeritics). ... mL min ⁻¹). Carbon dioxide desorbed from the sample was on-line monitored with a quadrupole-type <i>mass spectrometer</i> (Thermo Onix ...	2910
Effect of Nitric Acid Treatment on Carbon Nanotubes (CNTs)-Cordierite Monoliths ...	X Yu, B Lin, B Gong, J Lin, R Wang, K Wei - Catalysis Letters, 2008	... CO chemisorption was carried out with an AutoChem 2910 instrument (Micromeritics). ... The effluents (m/e = 28 for CO, 44 for CO ₂) were monitored by an online <i>mass spectrometer</i> (Pfeiffer vacuum, OmniStar). 2.4 Activity Studies ...	2910
Effect of Organic Nickel Precursor on the Reduction Performance and ...	F Li, X Yi, W Fang - Catalysis Letters, 2009	... The temperature-programmed desorption (TPD) experiments were performed on a Micromeritics AutoChem II 2920 instrument. ... C min ⁻¹ in a flow of Ar (40 mL min ⁻¹). H ₂ desorption was monitored by an online ThermoStar quadrupole <i>mass spectrometer</i> (model GSD301T2). ...	2920
Effect of Pt Impregnation on a Precipitated Iron-based Fischer–Tropsch Synthesis ...	W Yu, B Wu, J Xu, Z Tao, H Xiang, Y Li - Catalysis Letters, 2008	... CO temperature-programmed reduction (CO-TPR) experiment was carried out in a Micromeritics AutoChem G 2920 analyzer and an on-line <i>mass spectrometer</i> (QIC20). In CO-TPR experiment, about 100 mg of catalyst was loaded in a U-shape quartz tube flow reactor. ...	2920
Effect of Rh loading on the performance of Rh/Al ₂ O ₃ for methane partial oxidation to synthesis gas	Li, J.M., Huang, F.Y., Weng, W.Z., Pei, X.Q., Luo, C.R., Lin, H.Q., Huang, C.J., Wan, H.L., Catalysis Today, 131 (1), p.179-187, Feb 2008	...quadrupole <i>mass spectrometer</i> (Pfeiffer...oC using a Micromeritics Tristar 3000...performed by a Micromeritics AutoChem II 2920 instrument...quadrupole <i>mass spectrometer</i> (Pfeiffer...quadrupole <i>mass spectrometer</i> for the reaction...	2920
Effect of Ru on LaCoO ₃ perovskite-derived catalyst properties tested in oxidative reforming of diesel	Navarro, R.M., Alvarez-Galvan, M.C., Villoria, J.A., Gonzalez-Jimenez, I.D., Rosa, F., Fierro, J.L.G., Applied Catalysis B, Environmental, 73 (3), p.247-258, May 2007	...measurements were performed with a Micromeritics ASAP 2100 apparatus on samples...catalysts were conducted using a Micromeritics 2900 instrument in a U-shaped quartz...on-line with a quadrupole <i>mass spectrometer</i> (Balzers QMS 200), allowing...	2900
Effect of structural and acidity/basicity changes of CuO–CeO ₂ catalysts on their ...	P Djinović, J Levec, A Pintar - Catalysis Today, 2008	... of a U-shaped quartz test tube (designed to minimize channeling effects), which was inserted into an electric furnace of the Micromeritics' AutoChem apparatus. ... WGS reaction products as well as unconverted reactants were continuously recorded with a <i>mass spectrometer</i>	AutoChem
Effect of the nature of the support on the enantioselective hydrogenation of ... [86K]	TERESITA MARZIALETTI, J.L.G. FIERRO, P. REYES, Facultad de Ciencias, Jun 2009	...was studied in a TPR/TPD 2900 Micromeritics system equipped with a thermal...2 at 77 K in an automatic Micromeritics system Model ASAP 2010. The...analyzed in a gas chromatograph- <i>mass spectrometer</i> (GCMS-QP5050 Shimadzu...	2900

Effect of the preparation technique on the catalytic performances of TiO₂ supported ...	MP Casaletto, L Lisi, G Mattogno, P Patrono, F Pinzari, ... - Catalysis Today, 2004	... Temperature programmed reduction (TPR) with H ₂ and temperature programmed desorption (TPD) of NH ₃ were carried out using a Micromeritics TPD/TPR 2900 analyser equipped with a TC detector and coupled with a Hiden HPR 20 <i>mass spectrometer</i> as described in [3 ...	2900
Effect of the reductant nature on the catalytic removal of N₂O on Fe-zeolite-β ...	G Delahay, M Mauvezin, A Guzmán-Vargas, B ... - Catalysis ..., 2002	... Temperature programmed reduction analysis (TPR) by H ₂ /Ar (3/97) was carried out with a Micromeritics AutoChem 2910 apparatus using TCD ... For these TPR experiments, the detection was processed by a Pfeiffer Omnistar QMS 200 <i>mass spectrometer</i> and the masses 2 (H ₂ ...	2910
Effect of the Reduction Temperature of Co-La-Zr/AC on the Synthesis of Higher ...	G JIAO, Y DING, H ZHU, X LI, W DONG, J LI, Y ... - Chinese Journal of ..., 2009	... XRD analysis was carried out using a PANalytical X Pert PRO diffractometer. Temperature-programmed reduction (TPR) experiments were performed on a Micromeritics AutoChem 2910 apparatus, and an Omnistar 300 quadrupole <i>mass spectrometer</i> was used for detection. ...	2910
Effect of the support on the kinetic and deactivation performance of Pt/support catalysts during coupled hydrogenation...	Castano, P., Gutierrez, A., Pawelec, B., Fierro, J.L.G., Aguayo, A.T., Arandes, J.M., Applied Catalysis A, General, 333 (2), p.161-171, Dec 2007	...obtained in a Micromeritics ASAP 2010 instrument... Micromeritics TPO/TPR 2900 apparatus. Before...recorded using a <i>mass spectrometer</i> quadrupole...attached to a <i>mass spectrometer</i> quadrupole...recorded by the <i>mass spectrometer</i> and the area...	2900
Effect of ultrasonic power on the structure of activated carbon and the activities of ...	F Yu, J Ji, Z Xu, H Liu - Ultrasonics, 2006	... Surface oxygen groups analysis was performed employing a TPD-MS equipment (Micromeritics AutoChem 2910) with a quartz reactor containing 100 mg catalyst. ... 1. Desorption products of CO (m/e = 28) and CO ₂ (m/e = 44) were detected by an Omnistar <i>mass spectrometer</i>	2910
Effect of ultrasound in enantioselective hydrogenation of 1-phenyl-1, 2- ...	B Toukoniitty, E Toukoniitty, P Mäki-Arvela, JP ... - Ultrasonics- ..., 2006	... Temperature programmed desorption (TPD) of hydrogen was carried out with an AutoChem 2910 instrument (Micromeritics). The desorbed gases were identified and analyzed by a TC detector and a quadrupole <i>mass spectrometer</i> (Carlo Erba Instruments). ...	2910
Effect of vanadium on the behaviour of unsulfated and sulfated Ti-pillared clay ...	J Arfaoui, LK Boudali, A Ghorbel, G Delahay - Catalysis Today, 2009	... by temperature-programmed desorption (TPD) of ammonia using an AUTOCHEM 2910 (Micromeritics). ... programmed reduction have been carried out in the AUTOCHEM 2910 with a ... were analysed by sampling on line with a quadruple <i>mass spectrometer</i> (Pfeiffer Omnistar ...	2910
Effects of calcination temperatures on the catalytic performance of Rh/Al₂O₃ for methane partial oxidation to...	WZ Weng, XQ Pei, JM Li, CR Luo, Y Liu, HQ Lin, CJ ... - Catalysis Today, 2006	... The TPSR experiments were performed by a Micromeritics AutoChem II 2920 instrument using CH ₄ /O ₂ /He = 2/1/45 mixture (in the volume ratio) as ... The products of the TPSR reaction were analyzed by an on-line ThermoStar quadrupole <i>mass spectrometer</i> (GSD301T2). ...	2920
Effects of CeO₂ addition on Ni/Al₂O₃ catalysts for the reaction of ammonia ...	W Zheng, J Zhang, Q Ge, H Xu, W Li - Applied Catalysis B, Environmental, 2008	... A Micromeritics ASAP 2010P automated physisorption instrument was used to measure the N ₂ ... NH ₃ -TPSR experiments were carried out in a commercial Micromeritics AutoChem 2910 apparatus. ... K. The TPSR process was monitored by an on-line <i>mass spectrometer</i> (Omnisorp. ...	2910

Effects of palladium loading on the response of a thick film flame-made ZnO ...mdpi.org	C Liewhiran, S Phanichphant - Sensors, 2007 - mdpi.org	... Page 7. Sensors 2007, 7 1165 He, Micromeritics AutoChem II 2920 unit). ... reached. The recovery times, T rec denotes the time needed until 90% of the original baseline signal is recovered [52, 53]. Furthermore, the experimental set up had a <i>mass spectrometer</i> (MS) connected for ...	2920
Enhanced catalytic activity for butane isomerization with alumina-promoted tungstated mesoporous zirconia	Hwang, C.C., Chen, X.R., Wong, S.T., Chen, C.L., Mou, C.Y. , Applied Catalysis A, General, 323, p.9-17, Apr 2007	...porosity data were determined at 77K on a Micromeritics ASAP 2010 instrument. Ultraviolet-visible...samples was carried out on Micromeritics AutoChem 2910 instrument. Before NH ₃ adsorption...process was monitored by a Quadruple <i>Mass spectrometer</i> (Thermo ONIX ProLab) using the mass...	2910
Enhanced Hydrogen Storage Performance of LiBH ₄ -SiO ₂ -TiF ₃ Compositedicp.ac.cn	Y Zhang, WS Zhang, MQ Fan, SS Liu, ... - Journal of Physical ... , 2008 - taozhang.dicp.ac.cn	... TPD was conducted on Micromeritics AutoChem II under 0.1 MPa argon, to which a <i>mass spectrometer</i> (Omnistar) was attached for characterizing the liberated gases. TG measurements were executed upon TherMax 500 (Thermo Cahn). ...	2920
Enhancement of the CO ₂ retention capacity of X zeolites by Na- and Cs-treatments	Diaz, E., Munoz, E., Vega, A., Ordonez, S. , Chemosphere, 70 (8), p.1375-1382, Feb 2008	...at -196 ^o C on a Micromeritics ASAP 2000 instrument...by NH ₃ -TPD, in a Micromeritics TPD- 2900 apparatus connected to a Glaslab 300 <i>mass spectrometer</i> using He as the...baseline of the <i>mass spectrometer</i> . The TPD tests were...	2900
Ethanol steam reforming and water gas shift reaction over Co-Mn/ZnO catalysts	A Casanovas, C de Leitenburg, A Trovarelli, J ... - Chemical Engineering ... , 2009	... Temperature programmed reduction (TPR) was carried out with a Micromeritics AutoChem II 2920 instrument using a H ₂ /Ar mixture (5% H ₂) at 10 K min ⁻¹ and a TCD detector. ... The effluent of the reactor was monitored on line with a MKS Cirrus <i>mass spectrometer</i>	2920
Ethanol steam reforming over Co-based catalysts: Role of oxygen mobility	H Song, US Ozkan - Journal of Catalysis, 2009	... Temperature-programmed oxidation (TPO) experiments were performed using AutoChem-2920 (Micromeritics) with an online <i>mass spectrometer</i> (MS) (MKS Instruments, 1-300 amu). The samples were first pretreated at 300 ...	2920
Evaluating the Catalytic Performances of SAPO-34 Catalysts for the Oxidative ...	L Lisi, L Marchese, HO Pastore, A Frache, G ... - Topics in Catalysis, 2003	... Temperature-programmed desorption of NH ₃ (NH ₃ -TPD) measurements were carried out on the activated catalysts using a Micromeritics TPD/TPR 2900 analyzer equipped with a TC detector and coupled with a Hiden HPR 20 <i>mass spectrometer</i>	2900
Evaluation of different zeolites in their parent and protonated forms for the catalytic combustion of hexane and benzene	Diaz, E., Ordonez, S., Vega, A., Coca, J. , Microporous and Mesoporous Materials, 83 (1), p.292-300, Sep 2005	...adsorption at -196 ^o C with a Micromeritics ASAP 2000 surface analyser...studies were carried out using a Micromeritics TPD- 2900 apparatus connected to a mass...using a Glaslab 300 quadrupole <i>mass spectrometer</i> , which used a capillary inlet...	2900
Evolution of the properties of PtGe/Al ₂ O ₃ reforming catalysts with Ge content	R Mariscal, JLG Fierro, JC Yori, JM Parera, JM ... - Applied Catalysis A, ... , 2007	... Temperature-programmed reduction (TPR) profiles were taken on a semiautomatic Micromeritics TPD/TPR 2900 apparatus interfaced with a microcomputer. ... heating rate of 10 °C min ⁻¹ . The desorbing species were detected with a quadrupole <i>mass spectrometer</i> (Balzers QMG ...	2900
Experimental techniques for investigating the surface oxygen formation in the N ₂ O ...	A Ates, A Reitzmann - Chemical Engineering Journal, 2007	... studies of N ₂ O decomposition were performed in a set-up for catalyst characterisation (AutoChem 2910, Micromeritics) containing a quartz glass reactor (id 9 mm). The reaction products were monitored in an on-line mode using a quadrupole <i>mass spectrometer</i> (QMS 422 ...	2910

<p>Factors affecting isomer yield for n-heptane hydroisomerization over as- ...</p>	<p>S Gopal, PG Smirniotis - Journal of Catalysis, 2004</p>	<p>... The analysis was carried out using a Micromeritics AutoChem 2910 automated catalyst characterization system. ... Product identification was accomplished using a gas chromatograph (Hewlett-Packard, 5890 Series II) equipped with a <u>mass spectrometer</u> (Hewlett-Packard, 5972 ...</p>	<p>2910</p>
<p>Fe-Ce-ZSM-5 a new catalyst of outstanding properties in the selective ...rsc.org</p>	<p>G Carja, G Delahay, C Signorile, B Coq - Chemical Communications, 2004</p>	<p>... Temperature programmed reduction (TPR) by H₂/Ar (3/97) was carried out by using a Micromeritics AutoChem 2910 apparatus ... The effluent composition was monitored continuously by sampling on line to a quadrupole <u>mass spectrometer</u> (Pfeiffer vacuum Omnistar equipped ...</p>	<p>2910</p>
<p>Fine tuning the surface acid/base properties of single step flame-made Pt/alumina</p>	<p>B Schimmoeller, F Hoxha, T Mallat, F Krumeich, ... - Applied Catalysis A: ..., 2009</p>	<p>... Pt metal dispersion was determined by CO-pulse chemisorption on a Micromeritics AutoChem II 2920 unit. Off-gas was analyzed via a <u>mass spectrometer</u> (Pfeiffer Vacuum, ThermoStar) to derive the amount of chemisorbed CO [27]. ...</p>	<p>2920</p>
<p>Fischer-Tropsch synthesis over γ-alumina-supported cobalt catalysts: Effect of support variables</p>	<p>Borg, O., Eri, S., Blekkan, E.A., Storsaeter, S., Wigum, H., Rytter, E., Holmen, A. , Journal of Catalysis, 248 (1), p.89-100, May 2007</p>	<p>...Nitrogen adsorption/desorption isotherms were measured on a Micromeritics TriStar 3000 instrument, and the data were collected at...chemisorption Hydrogen adsorption isotherms were recorded on a Micromeritics ASAP 2010 unit at 312 K. The samples (0.5 g, 53-90 μm...</p>	
<p>Fischer-Tropsch synthesis over γ-alumina-supported cobalt catalysts: Effect of ...</p>	<p>Ø Borg, S Eri, EA Blekkan, S Storsaeter, H Wigum, E ... - Journal of Catalysis, 2007</p>	<p>... For one catalyst (C-11), TPR was performed on a Micromeritics AutoChem II instrument connected to a Pfeiffer Vacuum ThermoStar <u>mass spectrometer</u>. The sample was subjected to 10% H₂ in Ar while the temperature was increased from 300 to 1353 K at 10 K/min. ...</p>	<p>2920</p>
<p>Flame-derived Pt/Ba/Ce_xZr_{1-x}O₂: Influence of support on thermal deterioration ...</p>	<p>R Strobel, F Krumeich, SE Pratsinis, A Baiker - Journal of Catalysis, 2006</p>	<p>... programmed decomposition (TPD) of BaCO₃ was measured using a Micromeritics AutoChem II 2920 by heating (10 °C/min) 35 mg of powder in a helium flow (20 ml/min) from 50 to 1000 °C. Gas-phase composition was monitored by a <u>mass spectrometer</u> (Thermostar, Pfeiffer ...</p>	<p>2920</p>
<p>Flame-derived Pt/Ba/Ce_xZr_{1-x}O₂: Influence of support on thermal deterioration and behavior as NO_x...</p>	<p>Strobel, R., Krumeich, F., Pratsinis, S.E., Baiker, A. , Journal of Catalysis, 243 (2), p.229-238, Oct 2006</p>	<p>...the BET method (Micromeritics Tristar). Before...measured using a Micromeritics AutoChem II 2920 by heating...monitored by a <u>mass spectrometer</u> (Thermostar, Pfeiffer...analyzed using a <u>mass spectrometer</u> (Thermostar, Pfeiffer...</p>	<p>2920</p>
<p>Flame-made Pt-Ba/Al₂O₃ catalysts: Structural properties and behavior in lean-NO_x storage-reduction</p>	<p>Piacentini, M., Strobel, R., Maciejewski, M., Pratsinis, S.E., Baiker, A. , Journal of Catalysis, 243 (1), p.43-56, Oct 2006</p>	<p>...77 K using a Micromeritics Tristar 3000...Micromeritics AutoChem II 2920 instrument. A <u>mass spectrometer</u> (Pfeiffer Vacuum...Vacuum GSD 301 O1 <u>mass spectrometer</u>, which was connected...calibration of the <u>mass spectrometer</u> (injection of...</p>	<p>2920</p>

Flame-made Pt–Ba/Al₂O₃ catalysts: Structural properties and behavior in lean- ...	M Piacentini, R Strobel, M Maciejewski, SE Pratsinis, ... - Journal of Catalysis, 2006	... CO-pulse chemisorption was performed by injecting pulses (0.35 ml) of 10% CO/He into 5% H ₂ /Ar at 40 °C on a Micromeritics AutoChem II 2920 instrument. A <i>mass spectrometer</i> (Pfeiffer Vacuum, ThermoStar) was used to analyze the off-gas and derive the amount of ...	2920
Formation of the Surface NO during N₂O Interaction at Low Temperature with Iron- ...epfl.ch	DA Bulushev, A Renken, L Kiwi-Minsker - J. Phys. Chem. B, 2006	... Transient Response and TPD Measurements. Transient response and TPD experiments were performed in a Micromeritics AutoChem 2910 analyzer. A ThermoStar 200 (Pfeiffer Vacuum) quadrupole <i>mass spectrometer</i> was used for gas analysis. ...	2910
Ga-promoted tungstated zirconia catalyst for n-butane isomerization	XR Chen, CL Chen, NP Xu, S Han, CY Mou - Catalysis Letters, 2003	... The temperature-programmed desorption of ammonia (NH ₃ TPD) was carried out using a Micromeritics Auto-Chem 2910 instrument. ... The desorption process was monitored by a quadrupole <i>mass spectrometer</i> (Thermo ONIX, ProLab) connected on-line through a heated ...	2910
Gas chromatography / mass spectrometry analysis of components of pyridine temperature-programmed desorption spectra from...	Pribylova, L., Dvorak, B., Journal of Chromatography A, 1216 (18), p.4046-4050, May 2009	... TPD apparatus AutoChem 2920 with the...very sensitive <i>mass spectrometer</i> (MS). Application...commercial device AutoChem 2920 from Micromeritics corp. Two peripheral...joined to the AutoChem 2920 . The gas...equipped with a <i>mass spectrometer</i> for the qualitative...	2920
Gas-phase dehydration of glycerol over ZSM-5 catalysts	YT Kim, KD Jung, ED Park - Microporous and Mesoporous Materials, 2009	... programmed oxidation (TPO) was conducted over 0.05 g of the sample in a 2% O ₂ /He stream by heating the sample from 30 to 800 °C at a heating rate of 10 °C/min while monitoring the TCD signal (AutoChem 2910 unit, Micromeritics) and on-line <i>mass spectrometer</i> (QMS 200 ...	2910
Gas-phase hydrogenation of o-xylene over Pt/alumina catalyst, activity, and ...	A Kalantar Neyestanaki, P Mäki-Arvela, H Backman, ... - Journal of Catalysis, 2003	... Temperature-programmed desorption (TPD) of hydrogen and o-xylene was carried out with an AutoChem 2910 instrument (Micromeritics). The desorbed gases were identified and analyzed by a TC detector and a quadrupole <i>mass spectrometer</i> (Omnistar, Baltzer Instruments). ...	2910
Gas-phase hydrogenation of o-xylene over Pt/knitted silica-fiber catalysts	AK Neyestanaki, P Maki-Arvela, H ... - Ind. Eng. Chem. ..., 2003	... programmed desorption (TPD) of ammonia, hydrogen, and o-xylene was carried out in a volumetric equipment (AutoChem 2910 , Micromeritics) in the ... Desorbed gases were identified and analyzed by a quadrupole <i>mass spectrometer</i> (Omnistar, Baltzer Instruments). ...	2910
Highly active structured catalyst made up of mesoporous Co₃O₄ nanowires ...	G Marbán, I López, T Valdés-Solís, AB ... - International Journal of ..., 2008	... Nitrogen adsorption isotherms were performed at -196 °C on a Micromeritics ASAP 2020 volumetric adsorption system. ... TPR analyses were performed in a chemisorption analyzer (AutoChem II) equipped with a TCD reactor and a <i>mass spectrometer</i> (Omnistar 3000). ...	2920
Highly dispersed gold on activated carbon fibers for low-temperature CO oxidation	DA Bulushev, I Yuranov, EI Suvorova, PA Buffat, L ... - Journal of Catalysis, 2004	... in He (100 ml/min, ramp rate 10 K/min) using a Micromeritics AutoChem 2910 analyzer. In these experiments 0.010 g of ACF was placed in a quartz plug-flow reactor. The TPD products were analyzed by a ThermoStar-200 quadrupole <i>mass spectrometer</i> (Pfeiffer Vacuum ...	2910
Highly dispersed sol-gel synthesized Cu-ZrO₂ materials as catalysts for oxidative ...	S Esposito, M Turco, G Bagnasco, C ... - Applied Catalysis A: ..., 2009	... samples treated in air flow at 340 °C using a 2% H ₂ /Ar mixture and an heating rate of 10 °C min ⁻¹ with a Micromeritics 2900 apparatus ... TCD detector allowed the analysis of H ₂ , CO (detection limit = 0.01%) CO ₂ , O ₂ , CH ₄ , CH ₃ OH, H ₂ O. A <i>mass spectrometer</i> Hiden was ...	2900

<p>Highly dispersed solgel synthesized CuZrO₂ materials as catalysts for oxidative steam reforming of methanol</p>	<p>Esposito, S., Turco, M., Bagnasco, G., Cammarano, C., Pernice, P., Aronne, A., Applied Catalysis A, General, 372 (1), p.48-57, Jan 2010</p>	<p>...at 77K were obtained by a Micromeritics Gemini II 2370 apparatus...rate of 10^oCmin-1 with a Micromeritics 2900 apparatus. Copper dispersion...O₂, CH₄, CH₃OH, H₂O. A <u>mass spectrometer</u> Hiden was employed for identification...</p>	<p>2900</p>
<p>Highly efficient heterogenous catalyst for acylation of alcohols and amines using ...</p>	<p>B Sreedhar, R Arundhathi, MA Reddy, G ... - Applied Clay ..., 2009</p>	<p>... Programmed Desorption (TPD) studies were conducted on an AutoChem 2910 Micromeritics ... area measurements of samples were performed on a Micromeritics ASAP2020 automated ... sample were monitored online by a quadrapole <u>mass spectrometer</u></p>	<p>2910</p>
<p>HOT GAS DESULFURIZATION BY ZINC OXIDE-TITANIUM DIOXIDE REGENERABLE SORBENTS.</p>	<p>6-Feb</p>	<p>...RU300 inshument. Specific surface area was measured with a Micromeritics Flow Sorb II 2300 BET apparatus. The pore volume and pore size distribution were determined by 3 Micromeritics Autopore 9200. Reactions were performed in a Cahn 113-X...</p>	
<p>Hydrogen peroxide decomposition over Ln_{1-x}AxMnO₃ (Ln= La or Nd and A= K or ...</p>	<p>YN Lee, RM Lago, JLG Fierro, J González - Applied Catalysis A, General, 2001</p>	<p>... Temperature programmed reduction (TPR) and O₂ temperature programmed desorption (TPO) profiles were obtained in a Micromeritics 2900 instrument. ... at 10 K min⁻¹ and the desorption products O₂, CO₂ and H₂O monitored by a <u>mass spectrometer</u> detector Balzers QMG ...</p>	<p>2900</p>
<p>Hydrogen production by steam reforming of vegetable oils using nickel-based ...urv.es</p>	<p>M Marquevich, X Farriol, F Medina, D Montane - Ind. Eng. Chem. Res, 2001</p>	<p>... Hydrogen chemisorption was measured by pulses with a Micromeritics AutoChem 2910 instrument equipped with a TCD detector. ... qualitatively to monitor the extent of cracking by GC-MS using a Hewlett-Packard 5890 chromatograph with a 5989A <u>mass spectrometer</u> system. ...</p>	<p>2910</p>
<p>HYDROGEN TRANSFER PROPERTIES OF SOME COAL PROCESS RECYCLE SOLVENTS.</p>	<p>6-Mar</p>	<p>...101, and a flame ionization detector. Gc-ms data were obtained using a Hewlett-Packard 59958 gas chromatograph/<u>mass spectrometer</u> f i t t e d with the same column. Exchange experiments were done using three different Gc analyses were obtained 1 deuterium...</p>	
<p>Hydroisomerization in liquid phase of a refinery naphtha stream over Pt-Ni/H-beta zeolite catalysts</p>	<p>Funez, A., De Lucas, A., Sanchez, P., Ramos, M.J., Valverde, J.L., Chemical Engineering Journal, 136 (2), p.267-275, Mar 2008</p>	<p>...data acquired on a Micromeritics ASAP 2010 apparatus...ammonia (TPDA) using a Micromeritics TPD/TPR 2900 analyzer. The sample...Micromeritics TPD/TPR 2900 analyzer). After...SHIMADZU) coupled to a <u>mass spectrometer</u> (QP-5000 SHIMADZU...</p>	<p>2900</p>
<p>Hydroisomerization of n-hexane over gallium-promoted sulfated zirconia</p>	<p>C Cao, S Han, CL Chen, NP Xu, CY Mou - Catalysis Communications, 2003</p>	<p>... desorption (TPD) of ammonia was carried out on a Micromeritics AutoChem 2910 instrument. TPD profile of ammonia was obtained from 120 to 800 °C at a heating rate of 10 °C/min. The desorption process was monitored by a Quadruple <u>Mass spectrometer</u> (Thermo ONIX ...</p>	<p>2910</p>
<p>Hydrothermal Fabrication and Catalytic Properties of YBa₂Cu₃O₇ Single ...</p>	<p>Y Zhang, L Zhang, J Deng, H Dai, H He - Catalysis Letters</p>	<p>... Hydrogen temperature-programmed reduction (H₂-TPR) experiments were conducted on a Micromeritics AutoChem II 2920 chemical adsorption apparatus. ... The outlet gases were analyzed on-line by a <u>mass spectrometer</u> (Hiden HPR20). ...</p>	<p>2920</p>

<p>Identification of Iron Species in Fe- BEA: Influence of the Exchange Level</p>	<p>M Mauvezin, G Delahay, B Coq, S Kieger, JC ... - J. Phys. Chem. ..., 2001</p>	<p>... TPR by H₂ was carried out with a Micromeritics AutoChem 2910 apparatus using TCD detection. ... For these TPR experiments, the detection was processed by a Pfeiffer Omnistar QMS 200 <i>mass spectrometer</i>, and the masses 2 (H₂), 18 (H₂O), 28 (N₂ or CO), 30 (NO), 32 (O₂) ...</p>	<p>2910</p>
<p>Implication of the acid-base properties of V/Ti-oxide catalyst in toluene partial oxidation</p>	<p>Kiwi-Minsker, L., Bulushev, D.A., Rainone, F., Renken, A., Journal of Molecular Catalysis A: Chemical, 184 (1), p.223-235, Jun 2002</p>	<p>...Balzers QMG-421 <i>mass spectrometer</i> and a Perkin-Elmer...factors of the <i>mass spectrometer</i> for carbon oxides...performed via a Micromeritics AutoChem 2910 analyser with...200 quadrupole <i>mass spectrometer</i> (Pfeiffer Vacuum...)</p>	<p>2910</p>
<p>Implication of the acid-base properties of V/Ti-oxide catalyst in toluene partial ...epfl.ch</p>	<p>L Kiwi-Minsker, DA Bulushev, F Rainone, A ... - Journal of Molecular ..., 2002</p>	<p>... Temperature-programmed reduction (TPR) experiments were performed via a Micromeritics AutoChem 2910 analyser with a quartz plug-flow reactor. Hydrogen concentration was determined by a ThermoStar 200 quadrupole <i>mass spectrometer</i> (Pfeiffer Vacuum). ...</p>	<p>2910</p>
<p>In situ Raman study on the partial oxidation of methane to synthesis gas over Rh/ ...</p>	<p>Y Liu, FY Huang, JM Li, WZ Weng, CR Luo, ML ... - Journal of Catalysis, 2008</p>	<p>... The reaction products were analyzed by an online Balzers OmniStar quadrupole <i>mass spectrometer</i> (model QMS 200). 2.3. ... The O₂ temperature-programmed desorption (O₂-TPD) experiments were performed with a Micromeritics AutoChem II 2920 instrument. The catalyst (...ThermoStar quadrupole <i>mass spectrometer</i> (model GSD301T2...)</p>	<p>2920</p>
<p>Independent control of metal cluster and ceramic particle characteristics during one ...</p>	<p>H Schulz, L Madler, R Strobel, R Jossen, SE ... - Journal of Materials ..., 2005 - mrs.org</p>	<p>... Micromeritics AutoChem II 2920 by heating the particles in O₂ (20 ml min⁻¹, Pan Gas, 99.999%) up to 900 °C with 10 °C min⁻¹ and monitoring the evolving CO₂ and CO with a mass spectrometer (ThermoStar, Asslar, Germany, Pfeiffer Vacuum). The <i>mass spectrometer</i> ...</p>	<p>2920</p>
<p>INFLUENCE OF BASIC PROPERTIES OF Mg, Al-MIXED OXIDES ON THEIR ...sbq.org.br</p>	<p>CN Pérez, JLF Monteiro, JML Nieto, CA Henriques - quimicanova.sbq.org.br</p>	<p>... TPD analyses were run under He at a heating rate of 20 K min⁻¹ up to 723 K. The amount of CO₂ chemisorbed and its desorption profile were measured on a Micromeritics 2900 TPR/TPD analyzer with a quadrupole <i>mass spectrometer</i> detector (Balzers QMS-200). ...</p>	<p>2900</p>
<p>Influence of catalyst treatments on the adsorption properties of \pm-Al₂O₃ supported Pt, Rh and Ru catalysts</p>	<p>Diaz, E., Ordonez, S., Vega, A., Coca, J., Microporous and Mesoporous Materials, 77 (2), p.245-255, Jan 2005</p>	<p>...nitrogen adsorption with a Micromeritics ASAP 2000 apparatus) and...experiments were carried out in a Micromeritics TPD/TPR 2900 apparatus connected to an...released HCl, CO₂ and NO with a <i>mass spectrometer</i>, as the main metal precursors...</p>	<p>2900</p>
<p>Influence of clay binder on the liquid phase hydroisomerization of n-octane over ...</p>	<p>A De Lucas, P Sánchez, A Fúnez, MJ Ramos, ... - Journal of Molecular ..., 2006</p>	<p>... of the acid sites was measured by temperature programmed desorption of ammonia (TPDA) using a Micromeritics TPD/TPR 2900 analyzer. ... Liquid products were analyzed in a gas chromatograph (GC-17A SHIMADZU) coupled to a <i>mass spectrometer</i> (QP-5000 SHIMADZU). ...</p>	<p>2900</p>

<p>Influence of iron promoter on catalytic properties of Rh-Mn-Li/SiO₂ for CO hydrogenation</p>	<p>Yin, H., Ding, Y., Luo, H., Zhu, H., He, D., Xiong, J., Lin, L., Applied Catalysis A: General, 243 (1), p.155-164, Mar 2003</p>	<p>...was performed on an America Micromeritics AutoChem 2910. Eighty milligrams of...₂O that was provided by Micromeritics. 2.3.2 CO uptakes The apparatus...ml/min) with a quadrupole <i>mass spectrometer</i> (QMS, Balzers OmniStar 300...</p>	<p>2910</p>
<p>Influence of lanthanum on the performance of Zr-Co/activated carbon catalysts in ...</p>	<p>T Wang, Y Ding, Y Lü, H Zhu, L Lin - Journal of Natural Gas Chemistry, 2008</p>	<p>... Temperature programmed desorption of adsorbed CO Temperature programmed desorption of adsorbed CO (CO-TPD) was carried out on a flow apparatus of America Micromeritics AutoChem 2910 ... The product was detected simultaneously by a quadrupole mass-spectrometer. ...</p>	<p>2910</p>
<p>Influence of Morphological, Redox and Surface Acidity Properties on WGS Activity ...</p>	<p>P Djinovic, J Batista, J Levec, A Pintar - JOURNAL OF CHEMICAL ..., 2009 - J-STAGE</p>	<p>... Decomposition of N₂O and formation of N₂ were monitored with a <i>mass spectrometer</i> from Pfeiffer-Vacuum (model ThermoStar). ... quartz test tube (designed to minimize channeling effects), which was inserted into an electric furnace of the Micromeritics AutoChem II 2920 ...</p>	<p>2920</p>
<p>Influence of oxidation on heat-treated activated carbon support properties and ...</p>	<p>H Zhu, W Han, H Liu - Catalysis Letters, 2007</p>	<p>... The ash content was determined by heating in air at 800 °C to constant weight. The surface functional groups were determined by TPD-MS, which was performed on a Micromeritics AutoChem 2910 attached to a QMS 200 (Omnistar) <i>mass spectrometer</i>. ...</p>	<p>2910</p>
<p>Influence of Potassium Doping on the Formation of Vanadia Species in V/Ti Oxide ...epfl.ch</p>	<p>DA Bulushev, F Rainone, L Kiwi-Minsker, A Renken - Langmuir, 2001</p>	<p>... Temperature-Programmed Reduction. A Micromeritics AutoChem 2910 analyzer with a quartz plug-flow reactor was used for the TPR studies. The products in the reactor outlet were analyzed by a ThermoStar quadrupole <i>mass spectrometer</i> (Pfeiffer Vacuum). ...</p>	<p>2910</p>
<p>Influence of Pr and Ce in dry methane reforming catalysts produced from La_{1-x}AxNiO₃-&#948; perovskites</p>	<p>Gallego, G.S., Marin, J.G., Batiot-Dupeyrat, C., Barrault, J., Mondragon, F., Applied Catalysis A, General, 369 (1), p.97-103, Nov 2009</p>	<p>...experiments were carried out in a Micromeritics AutoChem 2910 using about 160mg of...isotherms were obtained in a Micromeritics Flowsorb II 2300 apparatus...analyzed by an on-line <i>mass spectrometer</i>. The reproducibility of...</p>	<p>2910</p>
<p>Influence of preparation methods of LaCoO₃ on the catalytic performances in the ...</p>	<p>JP Dacquain, C Lancelot, C Dujardin, P Da ... - Applied Catalysis B, ..., 2009</p>	<p>... H₂ -temperature-programmed reduction experiments (H₂ -TPR) were carried out in a Micromeritics AutoChem II 2920 with 5 vol.% H₂ in Ar and a gradual heating rate of 5 °C ... The outlet gas mixture was simultaneously analyzed using a GEV 010 Omnistar <i>mass spectrometer</i>. ...</p>	<p>2920</p>
<p>Influence of Pt location on BaCO₃ or Al₂O₃ during NO_x storage reduction</p>	<p>R Büchel, R Strobel, F Krumeich, A Baiker, SE ... - Journal of Catalysis, 2009</p>	<p>... The Pt dispersion was measured by CO-pulse chemisorption at 40 °C on a Micromeritics AutoChem II 2920. ... to 40 °C. Pulses of 0.35 mL 10% CO/He were injected in 10% H₂ /Ar and the CO concentration in the off gas was recorded using a <i>mass spectrometer</i> (Pfeiffer Vacuum ...</p>	<p>2920</p>
<p>Influence of textural properties of activated carbons on Pd/carbon catalysts synthesis for cinnamaldehyde hydrogenation</p>	<p>Cabiac, A., Cacciaguerra, T., Trens, P., Durand, R., Delahay, G., Medevielle, A., Plee, D., Coq, B., Applied Catalysis A, General, 340 (2), p.229-235, Jun 2008</p>	<p>...77K using a Micromeritics ASAP 2000...quadrupole <i>mass spectrometer</i> (Pfeiffer...apparatus (AutoChem 2910, Micromeritics), eventually...quadrupole <i>mass spectrometer</i> (Pfeiffer...2010 Chemi, Micromeritics) and using...</p>	<p>2910</p>

<p>Influence of the Al source and synthesis of ordered Al-SBA-15 hexagonal particles ...</p>	<p>W Li, SJ Huang, SB Liu, MO Coppens - Langmuir, 2005</p>	<p>... The acidic properties of the products were examined using temperature programmed desorption (TPD) of ammonia (Micromeritics TPD/TPR 2900). ... flow for 25 min to remove physically adsorbed NH₃. The NH₃ TPD spectra were detected by a <i>mass spectrometer</i> by increasing ...</p>	<p>2900</p>
<p>Influence of the nature of titanium source and of vanadia content on the properties of titanium-pillared montmorillonite</p>	<p>Arfaoui, J., Boudali, L.K., Ghorbel, A., Delahay, G., Journal of Physics and Chemistry of Solids, 69 (5), p.1121-1124, May 2008</p>	<p>...carried out at 77K using a Micromeritics ASAP 2000 and ATG, on a...Ar were carried out in an AUTOCHEM 2910 (Micromeritics). Before catalytic tests...O₂] = 3%) was monitored by <i>mass spectrometer</i> between 50 and 450°C. 3...</p>	<p>2910</p>
<p>Influence of the preparation method on the properties of Fe-ZSM-5 for the selective catalytic reduction of NO by...</p>	<p>Guzman-Vargas, A., Delahay, G., Coq, B., Lima, E., Bosch, P., Jumas, J.C., Catalysis Today, 107, p.94-99, Oct 2005</p>	<p>...N₂physisorption at 77K on a Micromeritics ASAP 2100 instrument, X-ray...H₂was carried out using a Micromeritics AutoChem 2910 instrument with thermal...sampling linked to a quadruple <i>mass spectrometer</i> (Pfeiffer Omnistar) equipped...</p>	<p>2910</p>
<p>Influence of thermal treatments on the basic and catalytic properties of Mg, ...scielo.br</p>	<p>RBIIV Zonno, IAV Santos, CA Henriques, JLF ... - Braz. J. Chem. ..., 2004 - SciELO Brasil</p>	<p>... basic sites distribution. The amount of CO₂ chemisorbed and its desorption profile for each sample were measured on a Micromeritics 2900 TPR/TPD analyzer with a quadrupole <i>mass spectrometer</i> detector. Prior to analysis ...</p>	<p>2900</p>
<p>Infrared spectroscopy, thermoprogrammed desorption, and nuclear magnetic ...</p>	<p>A Corma, C Corell, V Fornes, W Kolodziejski, J Pérez- ... - Zeolites, 1995</p>	<p>... cm⁻¹) were scaled according to the sample weight. Temperature programmed desorption experiments were done in a Micromeritics 2900 apparatus. The ... Unfortunately, our tpd, apparatus does not work on line with a <i>mass spectrometer</i>, so we have not been able to clarify ...</p>	<p>2900</p>
<p>Initiation step and reactive intermediates in the transformation of methanol into ...</p>	<p>AT Aguayo, AG Gayubo, R Vivanco, A Alonso, J ... - Ind. Eng. Chem. ..., 2005</p>	<p>... The runs of injection of methanol (or methanol and water) pulses have been carried out in an AutoChem II (Micromeritics) adsorption-desorption device connected on-line (by means of a thermostated line) to a <i>mass spectrometer</i> (Balzers Instruments). ...</p>	<p>2920</p>
<p>Inverse temperature dependence due to catalyst deactivation in liquid phase citral hydrogenation over Pt/Al₂O₃</p>	<p>Maki-Arvela, P., Kumar, N., Eranen, K., Salmi, T., Murzin, D.Yu., Chemical Engineering Journal, 122 (3), p.127-134, Sep 2006</p>	<p>...min and temperature programme 10K/min up to 923K (30min) by using Micromeritics (AutoChem 2910) apparatus and analyzing the desorbing gases by a quadrupole <i>mass spectrometer</i> (Balzers Instrument, Omnistar). In the temperature programmed oxidation...</p>	<p>2910</p>
<p>Investigation of the catalytic performances of supported noble metal based catalysts in the NO+H₂ reaction under lean...</p>	<p>Engelmann-Pirez, M., Granger, P., Leclercq, G., Catalysis Today, 107, p.315-322, Oct 2005</p>	<p>... Temperature-programmed reduction (TPR) was carried out in a Micromeritics AutoChem II 2920. Surface compositions were obtained by...4000h⁻¹. The effluents were analysed by a Balzers <i>mass spectrometer</i> and a HP 5890 series II chromatograph fitted...</p>	<p>2920</p>
<p>InVO₄-sensitized TiO₂ photocatalysts for efficient air purification with visible light</p>	<p>G Xiao, X Wang, D Li, X Fu - Journal of Photochemistry & Photobiology, A: ..., 2008</p>	<p>... volume of the samples were collected at 77 K using Micromeritics ASAP 2010 ... of oxygen (O₂ TPD) using a volumetric flow apparatus (AutoChem 2910, Micromeritics ... of the desorbed gases were performed continuously with a quadrupole <i>mass spectrometer</i> (Balzers OminiStar ...</p>	<p>2910</p>

<p>IR investigation of the interaction of deuterium with Ce_{0.6}Zr_{0.4}O₂ and Cl-doped Ce_{0.6}Zr_{0.4}O₂</p>	<p>Gennari, F.C., Montini, T., Hickey, N., Fornasiero, P., Graziani, M., Applied Surface Science, 252 (24), p.8456-8465, Oct 2006</p>	<p>...were obtained on a Micromeritics ASAP 2000 analyzer...Sensorlab quadropole <u>mass spectrometer</u>. Typically, 0.2g...capillary tube to the <u>mass spectrometer</u>. Analysis was performed...experiments with a Micromeritics TPD/TPR 2900 apparatus. After...</p>	<p>2900</p>
<p>Iridium-supported catalyst for enantioselective hydrogenation of 1-phenyl-1,2-propanedione: The effects of the addition...</p>	<p>Marzialetti, T., Fierro, J.L.G., Reyes, P., Catalysis Today, 107, p.235-243, Oct 2005</p>	<p>...using a gas chromatograph-<u>mass spectrometer</u> (GCMS-QP5050 Shimadzu) provided...was studied in a TPR/TPD 2900 Micromeritics system equipped with a thermal...of N₂at 77K in an automatic Micromeritics system Model ASAP 2010. The...</p>	<p>2900</p>
<p>Iron-catalyzed propylene epoxidation by nitrous oxide: Effect of boron on structure ...</p>	<p>S Yang, W Zhu, Q Zhang, Y Wang - Journal of Catalysis, 2008</p>	<p>... H₂ temperature-programmed reduction (H₂ -TPR), NH₃ temperature-programmed desorption (NH₃ -TPD), and CO₂ -TPD were performed using a Micromeritics AutoChem II 2920 instrument connected to a ThermoStar GSD 301 T2 <u>mass spectrometer</u>. ...</p>	<p>2920</p>
<p>Iron-catalyzed propylene epoxidation by nitrous oxide: Studies on the effects of ...</p>	<p>X Wang, Q Zhang, S Yang, Y Wang - J. Phys. Chem. B, 2005</p>	<p>... NH₃ -temperature-programmed desorption (NH₃ -TPD) was also carried out with the Micromeritics AutoChem II 2920 equipment, which was connected with a ThermoStar GSD 301 T2 <u>mass spectrometer</u> (Pfeiffer Vacuum). ...</p>	<p>2920</p>
<p>Kinetically controlled synthesis of carbon nanofibers with different morphologies by catalytic CO disproportionation...</p>	<p>Lu, W.-X., Sui, Z.-J., Zhou, J.-H., Li, P., Chen, D., Zhou, X.-G., Chemical Engineering Science, 65 (1), p.193-200, Jan 2010</p>	<p>...by an on-line <u>mass spectrometer</u> and the morphologies...308 to 1223K on Micromeritics AutoChem II 2920. N₂adsorption...carried out with Micromeritics ASAP 2010. Scan...line quadruple <u>mass spectrometer</u> (Questor, ABB...</p>	<p>2920</p>
<p>Kinetics and stereoselectivity of o-xylene hydrogenation over Pd/Al₂O₃</p>	<p>AK Neyestanaki, P Mäki-Arvela, H Backman, H ... - Journal of Molecular ..., 2003</p>	<p>... Auto Chem 2910, Micromeritics). Prior to the adsorption studies, the samples were reduced in situ at 673 K. For the H₂ -TPD studies, the hydrogen adsorption was carried out at 363 K. Desorbed gases were identified and analysed by a quadruple <u>mass spectrometer</u> (Omnistar ...</p>	<p>2910</p>
<p>Kinetics and thermodynamics of the Cr(III) adsorption on the activated carbon from ...</p>	<p>SI Lyubchik, AI Lyubchik, OL Galushko, LP ... - Colloids and Surfaces A: ..., 2004</p>	<p>... The carbon surfaces were characterized by Boehm titration methods and temperature-programmed desorption with Micromeritics TPD/TPR 2900 instrument using a quartz microreactor, which was connected to a <u>mass spectrometer</u> set-up (Fisons MD800) for continuous ...</p>	<p>2900</p>
<p>Kinetics and thermodynamics of the Cr(III) adsorption on the activated carbon from commingled wastes</p>	<p>Lyubchik, S.I., Lyubchik, A.I., Galushko, O.L., Tikhonova, L.P., Vital, J., Fonseca, I.M., Lyubchik, S.B., Colloids and Surfaces A: Physicochemical and Engineering Aspects, 242 (1), p.151-158, Aug 2004</p>	<p>...Area & Porosimetry Analyzer, Micromeritics ASAP 2010 (Table 1 Table...temperature-programmed desorption with Micromeritics TPD/TPR 2900 instrument using a quartz...which was connected to a <u>mass spectrometer</u> set-up (Fisons MD800) for...</p>	<p>2900</p>

Kinetics of H₂ recovery from dodecahydro-N-ethylcarbazole over a supported Pd ...	F Sotoodeh, L Zhao, KJ Smith - Applied Catalysis A, General, 2009	... was determined by pulsed chemisorption using the same Micromeritics AutoChem II 2920 ... A Micromeritics ASAP 2020 Accelerated Surface Area and Porosimetry analyzer was ... gas composition was continuously monitored using a quadrupole <i>mass spectrometer</i> (SRC Residual ...	2920
Kinetics of the NO/H₂ reaction on Pt/LaCoO₃: A combined theoretical and ...	F Dhainaut, S Pietrzyk, P Granger - Journal of Catalysis, 2008	... H ₂ temperature-programmed reduction (TPR) experiments were carried out on a Micromeritics AutoChem II 2920 instrument under a flow of ... The gaseous mixture was analysed using a Balzers quadrupole <i>mass spectrometer</i> and a Hewlett Packard 5890 series II chromatograph ...	2920
Kinetics of the NO+ H₂ reaction over supported noble metal based catalysts: ...	F Dhainaut, S Pietrzyk, P Granger - Applied Catalysis B, Environmental, 2007	... programmed reduction and hydrogen titration measurements, performed at 110 °C [9], were carried out on a Micromeritics AutoChem II 2920 ... The gaseous mixture was analysed by a Balzer <i>mass spectrometer</i> and a Hewlett Packard 5890 series II chromatograph fitted with a ...	2920
Kinetics of the NO+H₂ reaction over supported noble metal based catalysts: Support effect on their adsorption...	Dhainaut, F., Pietrzyk, S., Granger, P., Applied Catalysis B, Environmental, 70 (1), p.100-110, Jan 2007	...performed at 110°C[9], were carried out on a Micromeritics AutoChem II 2920 using a pulse technique. Prior to chemisorption...The gaseous mixture was analysed by a Balzer <i>mass spectrometer</i> and a Hewlett Packard 5890 series II chromatograph...	2920
Kinetics of Water-Gas-Shift-Reaction using MoS₂ catalyst dotted with Cofzk.de	HJ Ederer, T Fritsch, E Henrich, CE Mas - 2002 - fzk.de	... The activated catalyst CoMo-C49 was analysed with a surface investigation equipment AutoChem 2910 from Micromeritics company. ... The second analytic device was a quadrupole <i>mass spectrometer</i> of Pfeiffer company (Thermo Star 200) with 2 detectors (Faraday, CH ...	2910
Kinetics, catalyst deactivation and modeling in the hydrogenation of 2-sitosterol to 2-sitostanol over microporous and...	Maki-Arvela, P., Martin, G., Simakova, I., Tokarev, A., Warna, J., Hemming, J., Holmbom, B., (...), Murzin, D.Yu., Chemical Engineering Journal, 154 (1), p.45-51, Nov 2009	...dispersion was measured by pulse CO-chemisorption (Micromeritics AutoChem 2901). The catalyst was prerduced at 100...to 4bars. The raw material according to the <i>mass spectrometer</i> results contained: 82wt.% beta-sitosterol...	2910
L13psu.edu	M RAZISKOVALCI, Y RESEARCHERS - Poroilo o delu 2005 Annual report 2005 - Citeseer	... FIGURE: Automated system for heterogeneous catalysts characterization (Micromeritics , model AutoChem II 2920), connected to a <i>mass spectrometer</i> (Pfeiffer Vacuum, model Thermostar) employed as a secondary detector. Page 155. ...	2920
La, Ca and Fe oxide perovskites: preparation, characterization and catalytic properties for methane combustion	Ciambelli, P., Cimino, S., Lisi, L., Faticanti, M., Minelli, G., Pettiti, I., Porta, P., Applied Catalysis B: Environmental, 33 (3), p.193-203, Oct 2001	...reduction (TPR) experiments were performed as reported in [9] using a Micromeritics TPD/TPR 2900 analyzer equipped with a TC detector and coupled with a Hiden HPR 20 <i>mass spectrometer</i> . Samples (100 mg) were preheated in flowing air at 1073 K for 2...	2900

<p>Liquid-Impregnated Clay Solid Sorbents for CO Removal from Postcombustion Gas ...</p>	<p>R Siriwardane, C Robinson - Journal of Environmental Engineering, 2009 - link.aip.org</p>	<p>... reactor (Micromeritics AutoChem 2910, Norcross, Ga.) with the simulated flue-gas mix with moisture (by volume) at a flow rate of ; they were regenerated at with steam/nitrogen. The outlet gaseous mixture was analyzed by a Pfeiffer Vacuum Thermostar <i>mass spectrometer</i>. ...</p>	<p>2910</p>
<p>Liquid-phase hydroisomerization of n-octane over platinum-containing zeolite- ...</p>	<p>A de Lucas, P Sanchez, A Funez, MJ Ramos, JL ... - Ind. Eng. Chem., 2006</p>	<p>... of the acid sites was measured by temperature programmed desorption of ammonia (TPDA) using a Micromeritics TPD/TPR 2900 analyzer. ... Liquid products were analyzed in a gas chromatograph (GC-17A SHIMADZU) coupled to a <i>mass spectrometer</i> (QP-5000 SHIMADZU). ...</p>	<p>2900</p>
<p>Low temperature carbon monoxide oxidation over gold nanoparticles supported on sodium titanate nanotubes</p>	<p>JY Tsai, JH Chao, CH Lin - Journal of Molecular Catalysis. A, Chemical, 2009</p>	<p>... of the catalytic reactivity was performed in an AutoChem 2910 analyzer (Micromeritics) equipped with ... The AutoChem 2910 was operated in a pulse reactor mode, and its diagram ... The product mixture were analysed by an on-line quadrupole <i>mass spectrometer</i> (Prolab, Thermo ...</p>	<p>2910</p>
<p>Low temperature decomposition of nitrous oxide over Fe/ZSM-5: Modelling of the ...epfl.ch</p>	<p>L Kiwi-Minsker, DA Bulushev, A Renken - Catalysis Today, 2005</p>	<p>... reactivity of deposited oxygen and temperature-programmed desorption/reaction (TPD/TPR) experiments were performed in a Micromeritics AutoChem 2910 analyser provided with a quartz plug-flow reactor. A ThermoStar 200 (Pfeiffer Vacuum) mass-spectrometer was used to ...</p>	<p>2910</p>
<p>Low Temperature Water-Gas Shift/Methanol Steam Reforming: Alkali Doping to ...</p>	<p>HN Evin, G Jacobs, J Ruiz-Martinez, UM Graham, A ... - Catalysis Letters, 2008</p>	<p>... treated in-situ in a Micromeritics AutoChem II 2920 chemisorption analyzer under the following conditions: the samples were first reduced at 300 °C for 8 h ... CO₂ desorbed was measured by a Pfeiffer/Balzers Thermostar <i>mass spectrometer</i> coupled to the Micromeritics system. ...</p>	<p>2920</p>
<p>Low Temperature Water-Gas Shift: Alkali Doping to Facilitate Formate C-H Bond ...</p>	<p>HN Evin, G Jacobs, J Ruiz-Martinez, GA Thomas, BH ... - Catalysis Letters, 2008</p>	<p>... The catalysts were treated in-situ in a Micromeritics AutoChem II 2920 chemisorption analyzer under the following conditions: the samples were first reduced at 300 °C for 8 h ... was measured by a Pfeiffer/Balzers Thermostar <i>mass spectrometer</i> coupled to the Micromeritics system ...</p>	<p>2920</p>
<p>Low-temperature catalytic decomposition of N₂O on platinum and bismuth- ...rsc.org</p>	<p>R Burch, GA Attard, ST Daniells, DJ Jenkins, JP ... - Chemical, 2002</p>	<p>... Reaction products were monitored using a computer interfaced Fisons Gaslab 300 <i>Mass spectrometer</i>, operated using the corresponding ThermoSoft ... at 300 °C. Characterisation of the catalysts was achieved using H₂ and CO chemisorption (Micromeritics AutoChem 2910) and ...</p>	<p>2910</p>
<p>Low-Temperature Single-Wall Carbon Nanotubes Synthesis: Feedstock ...polyu.edu.hk</p>	<p>E Mora, JM Pigos, F Ding, BI Yakobson, AR ... - Journal of the, 2008</p>	<p>... by an impregnation method.(8) The catalyst reducibility was studied by temperature programmed reduction (TPR) in a Micromeritics AutoChem 2910 under 10% H ... A <i>mass spectrometer</i> (MS), attached at the gas outlet of the reactor, monitored the catalyst activity in situ during the ...</p>	<p>2910</p>

Manganese oxide catalysts supported on TiO₂, Al₂O₃, and SiO₂: a comparison for ...	PG Smirniotis, PM Sreekanth, DA Pena, RG ... - Ind. Eng. Chem. ..., 2006	... The temperature-programmed reduction experiments were carried out from 353 to 1223 K on a Micromeritics AutoChem 2910 instrument using 50 mg of ... oxygen for 2 h at 673 K. The reactants and products were analyzed online using a Quadrapole <i>mass spectrometer</i> (MKS PPT ...	2910
Manganese Oxide/Titania Materials for Removal of NO_x and Elemental Mercury ...	L Ji, PM Sreekanth, PG Smirniotis, SW Thiel, NG ... - Energy & Fuels, 2008	... programmed reduction (H ₂ -TPR) experiments were carried out from 80–950 °C using a Micromeritics AutoChem 2910 instrument ... The reactants and products were analyzed online using a Quadrapole <i>mass spectrometer</i> (MKS PPT-RGA), chemiluminescence detector (Eco ...	2910
Manganese-promoted Rh/Al₂O₃ for C₂-oxygenates synthesis from syngas - Effect of manganese loading	Ojeda, M., Granados, M.L., Rojas, S., Terrerós, P., Garcia-Garcia, F.J., Fierro, J.L.G. , Applied Catalysis A: General, 261 (1), p.47-55, Apr 2004	...experiments were carried out on a Micromeritics TPD/TPR 2900 apparatus. The catalyst...Prisma QMS 200 TM quadropole <i>mass spectrometer</i> . The catalyst was reduced...reactor connected to the <i>mass spectrometer</i> as described above. The...	2900
MCM-41 supported Mo/Zr mixed oxides as catalysts in liquid phase condensation of 2-methylfuran with acetone	Li, T., Cheng, S., Lee, J.-F., Jang, L.-Y. , Journal of Molecular Catalysis A: Chemical, 198 (1), p.139-149, May 2003	...nitrogen temperature with a Micromeritics ASAP 2000 apparatus. Transmission...TPD) was carried out on a Micromeritics AutoChem 2910 instrument. 50 mg of...monitored by a quadruple <i>mass spectrometer</i> (Thermo ONIX, ProLab) connected...	2910
Mesoporous silica-aluminas derived from precipitation: a study of the acidity, ...	M Bartoszek, R Eckelt, C Jäger, H Kosslick, A Pawlik ... - Journal of Materials Measurements were carried on an AutoChem 2910 (Micromeritics) apparatus that was coupled with a <i>mass spectrometer</i> to differentiate between ammonia and water desorption. Approximately, 100 mg of the sample was activated in flowing helium at elevated temperature. ...	2910
Methanation of carbon dioxide over the LaNiO₃ perovskite catalysts activated ...	J GAO... - Journal of Fuel Chemistry and Technology, 2009	... The sample was deposited on a Cu grid for TEM observation. H ₂ -temperature- programmed desorption (H ₂ -TPD) was performed on Micromeritics AutoChem 2920 II instrument connected to a ThermoStar GSD 301 T2 <i>mass spectrometer</i>	2920
Methane combustion and CO oxidation on LaAl_{1-x}Mn_xO₃ perovskite-type oxide ...	S Cimino, L Lisi, S De Rossi, M Faticanti, P ... - Applied Catalysis B, ..., 2003	... Temperature programmed reduction (TPR) experiments were performed using a Micromeritics TPD/TPR 2900 analyser equipped with a TC detector and coupled with a Hiden HPR 200 <i>mass spectrometer</i> . Samples (0.1 g) were ...	2900
Microwave plasma assisted preparation of Pd-nanoparticles with controlled dispersion on woven activated carbon fibres	Korovchenko, P., Renken, A., Kiwi-Minsker, L. , Catalysis Today, 102, p.133-141, May 2005	...for characterization of surface acidity using a Micromeritics AutoChem 2910 analyzer. For the TPD measurements 0.05g...analyzed by ThermoStar-200 quadrupole "on-line" mass-spectrometer (Pfeiffer Vacuum) calibrated with gas mixtures...	2910
Mild hydrogenation of quinoline - 2. A novel Rh-containing pillared layered clay catalyst	Campanati, M., Casagrande, M., Fagiolino, I., Lenarda, M., Storaro, L., Battagliarin, M., Vaccari, A. , Journal of Molecular Catalysis A: Chemical, 184 (1), p.267-272, Jun 2002	...carried out at 77 K using a Micromeritics ASAP 2010 . Before each measurement...measurements were performed using a Micromeritics AutoChem 2910 . High resolution TEM...thickness 0.25 μm) and <i>mass spectrometer</i> detector. 3 Results and discussion...	2910

Mild hydrogenation of quinoline 2. A novel Rh-containing pillared layered clay ...	M Campanati, M Casagrande, I Fagiolino, M ... - Journal of Molecular ..., 2002	... Hydrogen chemisorption measurements were performed using a Micromeritics AutoChem 2910 were carried out using a GC-MS Hewlett-Packard GCD 1800A system equipped with an HP-5 column (30 m×0.25 mm, film thickness 0.25 µm) and <i>mass spectrometer</i> detector. ...	2910
Modification of polystyrene-based activated carbon spheres to improve adsorption ...	Q Wang, X Liang, W Qiao, C Liu, X Liu, R Zhang, ... - Applied Surface ..., 2009	... acidity measurement [35]. TPD experiment was carried out on an AutoChem II 2920 (Micromeritics, USA) . A typical procedure ... 10 °C/min. The outlet gas was diverted to a quadrupole <i>mass spectrometer</i> (Questor, ABB Extrel, USA) for analysis. ...	2920
Modification of the adsorption properties of high surface area graphites by oxygen functional groups	Cuervo, M.R., Asedegbega-Nieto, E., Diaz, E., Ordonez, S., Vega, A., Dongil, A.B., Rodriguez-Ramos, I., Carbon, 46 (15), p.2096-2106, Dec 2008	...at -196°C with a Micromeritics ASAP 2000 surface...TPO), employing a Micromeritics TPD-2900 apparatus connected...Pfeiffer Vacuum-300 <i>mass spectrometer</i> . For this purpose...with a quadrupole <i>mass spectrometer</i> (Balzers QMG 421-C...	2900
Monodispersed Pd Nanoparticles for Acetylene Selective Hydrogenation: ...epfl.ch	M Ruta, N Semagina, L Kiwi- ... - The Journal of Physical ..., 2008 - infoscience.epfl.ch	... decom- position (TPD) in He (20 mL/min, ramp rate 20 K/min from room temperature up to 1273 K) using a Micromeritics AutoChem 2910 analyzer. The amounts of CO and CO ₂ desorbed were monitored with a ThermoStar-200 quadrupole <i>mass spectrometer</i> (Pfeiffer Vacuum ...	2910
Monolithic Pt/Ce0.8Zr0.2O2/cordierite catalysts for low temperature water gas shift reaction in the real...	Du, X., Gao, D., Yuan, Z., Liu, N., Zhang, C., Wang, S., International Journal of Hydrogen Energy, 33 (14), p.3710-3718, Jul 2008	...chemisorption at 40°C[21]was performed on Micromeritics AutoChem 2920 equipment, assuming that each...Pt dispersion measurements, using Micromeritics AutoChem 2920 equipped with a quantum <i>mass spectrometer</i> (OmniStar). The sample was heated...	2920
Morphology observation of carbon deposition by CH4 decomposition over Ni-based catalysts	Yonglai Yang, Hengyong Xu, Wenzhao Li, Nanotechnology, 16 (1), p.129-132, Jan 2005	...oxidation behaviour of the carbon de- posits on a Micromeritics AutoChem 2910 system. The cata- lysts after carbon deposition...deposits, were detected by an on-line Omnistar <i>mass spectrometer</i> . 3. Results and discussion The TEM images in...	2910
N2O decomposition over K-promoted Co-Al catalysts prepared from hydrotalcite-like precursors	Cheng, H., Huang, Y., Wang, A., Li, L., Wang, X., Zhang, T., Applied Catalysis B, Environmental, 89 (3), p.391-397, Jul 2009	...N ₂ O adsorption at -196°C using a Micromeritics ASAP 2010 apparatus. The X-r...experiments were carried out on a Micromeritics AutoChem II 2920 automated catalystcharacterization...was monitored online by a <i>mass spectrometer</i> (Omni-star, GSD-300), withm...	2920
Nanostructured CuxCe1-xO2-y mixed oxide catalysts: Characterization and WGS ...	A Pintar, J Batista, S Hočevar - Journal of colloid and interface science, 2007	... TPO, TPD-H ₂ , and selective N ₂ O pulse reaction measurements were performed using an automated Micromeritics AutoChem II 2920 ... samples CuCe-1 and CuCe-4) was done by TCD and MS detectors (computer-interfaced Pfeiffer Vacuum ThermoStar <i>mass spectrometer</i>). ...	2920
NEW Ni/MIEC CERMET ANODE FOR SOFC APPLICATIONS BASED ON ...inpl-nancy.fr	F MOSER, MT CALDES, O JOUBERT, V GARCIA- ... - perso.ensem.inpl-nancy.fr	... The temperature-programmed reduction (TPR) studies were performed in a chemisorption unit Micromeritics AutoChem 2910 with powder samples of 50 mg. ... The composition of the reactants / products mixture was analysed with an on-line <i>mass spectrometer</i>	2910

Nickel/alumina catalysts modified by basic oxides for the production of synthesis gas by methane partial oxidation	J Requies, MA Cabrero, VL Barrio, JF Cambra, MB ... - Catalysis Today, 2006	... A Micromeritics TPD/TPR 2900 apparatus equipped with a TCD was used for temperature-programmed reduction (TPR) analyses. ... on catalyst samples (50 mg) loaded in a U-shaped quartz reactor connected to a Baltzer Prisma QMS 200 TM quadrupole <i>mass spectrometer</i>	2900
Nonhydrolytic vanadia-titania xerogels: Synthesis, characterization, and behavior ...	PH Mutin, AF Popa, A Vioux, G Delahay, B ... - Applied Catalysis B, ..., 2006	... of ammonia (NH ₃ -TPD) and temperature-programmed reduction by H ₂ (H ₂ -TPR) were performed with a Micromeritics AutoChem 2910 apparatus ... O ₂ , N ₂ , H ₂ O, and N ₂ O were continuously monitored by on-line sampling to a quadrupole <i>mass spectrometer</i> (Balzers QMS ...	2910
Novel non-hydrolytic synthesis of a V₂O₅-TiO₂ xerogel for the selectiversc.org	AF Popa, PH Mutin, A Vioux, G Delahay, B ... - Chemical Communications, 2004	... was analysed by nitrogen physisorption at 77 K on a Micromeritics ASAP 2000 ... Temperature programmed desorption (TPD) of NH ₃ (Micromeritics AutoChem 2910) showed that the ... continuously monitored by on-line sampling to a quadrupole <i>mass spectrometer</i> (Balzers QMS 421 ...	2910
Novel Regenerable Sodium-Based Sorbents for CO₂ Capture at Warm Gas ...	RV Siriwardane, C Robinson, M Shen, T Simonyi - Energy Fuels, 2007	... Competitive gas adsorption and desorption studies were conducted in a lab-scale fixed-bed reactor (Micromeritics AutoChem 2910 atmospheric flow reactor) at 14.7 psi (1.01 × 10 ⁵ Pa ... The outlet gas stream was analyzed using a Pfeiffer Vacuum Thermostat <i>mass spectrometer</i>	2910
NOVEL STRUCTURED ADSORBER AND OXIDATION CATALYSTS FORepfl.ch	KM NIKOLAJSEN - biblion.epfl.ch	... Micromeritics Reactor GC Gas chromatograph ID Inner diameter IWI Incipient wetness impregnation LDF Linear driving force MS <i>Mass spectrometer</i> MS Mean square MTZ Mass transfer zone NMR Nuclear magnetic resonance OD Outer diameter ...	
Novel transformations amongst mesostructured VPO phases synthesized through surfactant assisted organization from an...	Datta, A., Sakthivel, S., Kaur, M., Venezia, A.M., Pantaleo, G., Longo, A., Microporous and Mesoporous Materials, 128 (1), p.213-222, Mar 2010	...reaction (TPR) measurements were conducted with a Micromeritics AutoChem 2910 Automated Catalyst Characterization System...the evolved gases were analysed by a quadrupole <i>mass spectrometer</i> . The average oxidation state of vanadium was...	2910
n-Pentane isomerization over platinum-promoted W/Zr mixed oxides supported on mesoporous silica	Li, T., Wong, S.-T., Chao, M.-C., Lin, H.-P., Mou, C.-Y., Cheng, S., Applied Catalysis A: General, 261 (2), p.211-219, Apr 2004	...nitrogen temperature with a Micromeritics ASAP 2000 apparatus. Transmission...TPD) was carried out on a Micromeritics AutoChem 2910 instrument. TPD profiles...monitored by a quadrupole <i>mass spectrometer</i> (Thermo ONIX, ProLab) connected...	2910
n-Pentane isomerization over promoted SZ/MCM-41 catalysts	W Wang, JH Wang, CL Chen, NP Xu, CY Mou - Catalysis Today, 2004	... The TPR and NH ₃ -TPD were carried out on a Micromeritics AutoChem 2910 instrument. ... The desorption process was monitored by a Quadruple <i>Mass spectrometer</i> (Thermo ONIX, ProLab) connected on-line through a heated capillary interface. ...	2910
Olivine catalysts for methane-and tar-steam reforming	JN Kuhn, Z Zhao, LG Felix, RB Slimane, CW ... - Applied Catalysis B, ..., 2008	... The effluent was monitored with a Cirrus RGA <i>mass spectrometer</i> using the Faraday detector. ... Temperature-programmed reduction (TPR) and oxidation (TPO) were performed with a Micromeritics AutoChem II 2920 equipped with a TCD. ...	2920

On the catalytic nature of Mn/sulfated zirconia for selective reduction of NO with ...dicp.ac.cn	N Li, A Wang, Z Liu, X Wang, M Zheng, Y ... - Applied Catalysis B, ..., 2006	... Temperature programmed reduction (TPR) experiments were carried out with Micromeritics AutoChem II 2920 Automated Catalyst Characterization System using an H ₂ ... NO-TPD was conducted on a flowing reaction system using a <i>mass spectrometer</i> (omni-star, GSD-300) as ...	2920
One-pot synthesis and characterization of metal phosphide-doped carbon xerogels	H Wang, Y Shu, A Wang, J Wang, M Zheng, X Wang, T ... - Carbon, 2008	... The carbothermal reduction process of the organic xerogels was monitored by running the temperature-programmed reaction on a Micromeritics AutoChem 2910 apparatus combining with an Ominatar <i>mass spectrometer</i> . Before ...	2910
Oxidation of pinane using transition metal acetylacetonate complexes immobilised on modified activated carbon	Valente, A., Botelho do Rego, A.M., Reis, M.J., Silva, I.F., Ramos, A.M., Vital, J., Applied Catalysis A: General, 207 (1), p.221-228, Feb 2001	...nitrogen at 77 K on a Micromeritics ASAP 2010 V1.01 B...MICROMERITCS TPD/TPR 2900 instrument by heating...stream was fed to a <i>mass spectrometer</i> through a heated line...fragmentation in the <i>mass spectrometer</i> , of imine 3 which...	2900
Oxidation of propane to acrylic acid over vanadyl pyrophosphate: modifications of the structural and acid properties...	Landi, G., Lisi, L., Volta, J.-C., Journal of Molecular Catalysis A: Chemical, 222 (1), p.175-181, Nov 2004	...TPD) was performed using a Micromeritics TPD/TPR 2900 analyser equipped with a...coupled with a Hiden HPR 20 <i>mass spectrometer</i> . After a pre-treatment at...oxides were followed with the <i>mass spectrometer</i> . In our experiments only...	2900
Oxidative dehydrogenation of ethane on γ-Al₂O₃ supported vanadyl and iron ...	MP Casaletto, L Lisi, G Matogno, P Patrono, G ... - Applied Catalysis A, ..., 2002	... TPR with hydrogen and TPD of NH ₃ were carried out using a Micromeritics TPD/TPR 2900 analyser equipped with a TC detector and coupled with a Hiden HPR 20 <i>mass spectrometer</i> . In the TPR experiments, the sample was ...	2900
Oxidative dehydrogenation of propane over catalysts based on carbon nanofibers	Z Sui, J Zhou, Y Dai, W Yuan - Catalysis Today, 2005	... creating products. TPD and TPSR runs were carried out on AutoChem II 2920 (Micromeritics, USA) . The outgoing gas was diverted to a quadrupole <i>mass spectrometer</i> (Questor, ABB Extrel, USA) to be analyzed. Concentrations ...	2920
Oxygen Exchange Kinetics over Sr-and Co-Doped LaFeO₃	JN Kuhn, PH Matter, JMM Millet, RB Watson, ... - The Journal of ..., 2008	... Temperature-Programmed Reoxidation Experiments were performed with an AutoChem II 2920 ... were performed by monitoring the effluent with a gas chromatograph/ <i>mass spectrometer</i> (GC/MS ... A Micromeritics ASAP 2010 instrument was used to treat samples under various ...	2920
Palladium based catalysts for exhaust aftertreatment of natural gas powered vehicles and biofuel combustion	Klingstedt, F., Neyestanaki, A.K., Byggningsbacka, R., Lindfors, L.-E., Lunden, M., Petersson, M., Tengstrom, P., (...), Vayrynen, J., Applied Catalysis A: General, 209 (1), p.301-316, Feb 2001	...detected using a quadrupole <i>mass spectrometer</i> (Carlo Erba Instruments...600 C (10 C/min) using a Micromeritics AutoChem 2910 equipped with a thermal...detected using a quadruple <i>mass spectrometer</i> . The surface composition...	2910
Palladium Catalysts Supported on Fishbone Carbon Nanofibers from Different ...	J ZHOU, Z SUI, X ZHOU, W YUAN - Chinese Journal of Catalysis, 2008	... The temperature-programmed desorption (TPD) experiments were carried out on an Auto- chem II 2920 (Micromeritics, USA) combined with a quadrupole <i>mass spectrometer</i> (Questor, ABB Extrel, USA). De- tailed procedures refer to the literature [10]. ...	2920

Palladium on carbon nanofibers grown on metallic filters as novel structured ...epfl.ch	P Tribolet, L Kiwi-Minsker - Catalysis today, 2005	... min, ramp rate 10 K/min) using a Micromeritics AutoChem 2910 analyzer. In these experiments about 80 mg of 6% CNF/SMF Inconel were placed in a quartz tubular reactor. The TPD products were analyzed by a ThermoStar-200 quadrupole <i>mass spectrometer</i> (Pfeiffer Vacuum ...	2910
Partial oxidation of toluene to benzaldehyde and benzoic acid over model vanadia/ ...epfl.ch	DA Bulushev, F Rainone, L Kiwi-Minsker - Catalysis Today, 2004	... Temperature programmed reduction (TPR) experiments were performed in a Micromeritics AutoChem 2910 analyser with a quartz plug-flow reactor. Hydrogen concentration was determined by a Thermostar 200 quadrupole mass-spectrometer (Pfeiffer Vacuum). ...	2910
Photocatalytic Generation of H₂ Gas from Neat Ethanol over Pt/TiO₂ Nanotube ...	CH Lin, CH Lee, JH Chao, CY Kuo, YC Cheng, WN ... - Catalysis Letters, 2004	... and 900 nm. TPD/NH ₃ experiments were performed with on a AutoChem 2910 automated catalyst characterization system (Micromeritics) interfaced with quadrupole <i>mass spectrometer</i> (Proleb, Thermo Onix). XRD spectra were ...	2910
Platinum catalysts on alumina and silica prepared by gas- and liquid- phase deposition in cinnamaldehyde hydrogenation	Lashdaf, M., Lahtinen, J., Lindblad, M., Venalainen, T., Krause, A.O.I., Applied Catalysis A: General, 276 (1), p.129-137, Nov 2004	...determined with a VG 7070E high-resolution <i>mass spectrometer</i> (MS). For MS analysis the samples were heated...method. The experiments were carried out with a Micromeritics TPD/TPR 2910 AutoChem instrument. The sample (100-200 mg) was set...	2910
Precursor Effect on the Molecular Structure, Reactivity, and Stability of Alumina- ...	AE Lewandowska, MA Bañares, DF Khabibulin, OB ... - 2009	... and temperature-programmed oxidation (TPR/TPO) experiments were performed in a fixed-bed quartz reactor fitted to a Micromeritics TPD/TPR 2900 analyzer. ... 823 K; then it was cooled to 323 K. The TPR/TPO treatments were recorded with a Hiden HPR20 <i>mass spectrometer</i>	2900
Preparation and characterization of LaCrO₃ and Cr₂O₃ methane combustion ...	MFM Zwinkels, O Haussner, P Govind Menon, SG ... - Catalysis Today, 1999	... Temperature-programmed reduction (TPR) of the powder samples was performed using a Micromeritics TPD/TPR 2900 , equipped with a thermal conductivity detector. ... The combustion products were analyzed on-line using a Balzers QMG 421C quadrupole <i>mass spectrometer</i>	2900
Preparation of Cobalt Nitride from Co–Al Hydrotalcite and its Application in ...dicp.ac.cn	H Cheng, Y Huang, A Wang, X Wang, T Zhang - Topics in Catalysis, 2009	... Temperature programmed reduction (TPR) experiments were carried out on a Micromeritics AutoChem II 2920 automated catalyst characterization system. ... The outlet gas was monitored online by a <i>mass spectrometer</i> (Omini-star, GSD- 300), with an m/z of 16 representing NH ₃ ...	2920
Preparation of Fischer-Tropsch cobalt catalysts supported on carbon nanofibers and silica using homogeneous...	Bezemer, G.L., Radstake, P.B., Koot, V., van Dillen, A.J., Geus, J.W., de Jong, K.P., Journal of Catalysis, 237 (2), p.291-302, Jan 2006	...Fisons Thermolab quadrupole <i>mass spectrometer</i> through a capillary situated...was executed with an AutoChem 2920 instrument from Micromeritics using a heating rate of...measurements were done with a Micromeritics ASAP 2010C. Before each...	2920
Preparation of Fischer–Tropsch cobalt catalysts supported on carbon nanofibers ...uu.nl	GL Bezemer, PB Radstake, V Koot, AJ Van Dillen, ... - Journal of Catalysis, 2006	... The gases evolved were monitored by a Fisons Thermolab quadrupole <i>mass spectrometer</i> through a capillary situated directly above the sample cup. Temperature-programmed reduction (TPR) was executed with an AutoChem 2920 instrument from Micromeritics using a ...	2920

Preparation, characterization and catalytic properties of carbon nanofiber-supported Pt, Pd, Ru monometallic particles...	Taboada, C.D., Batista, J., Pintar, A., Levec, J., Applied Catalysis B, Environmental, 89 (3), p.375-382, Jul 2009	...196°C using a Micromeritics ASAP 2020 MP... Micromeritics AutoChem II 2920 catalyst...Pfeiffer Vacuum <i>mass spectrometer</i> (model ThermoStar...out by TCD and <i>mass spectrometer</i> (MS) detectors...detector and <i>mass spectrometer</i> (MS). We observed...	2920
Pretreatments of Co ₃ O ₄ at moderate temperature for CO oxidation at -80° C	Y Yu, T Takei, H Ohashi, H He, X Zhang, M Haruta - Journal of Catalysis, 2009	... O ₂ -TPD and CO-TPR experiments were performed at Automated Catalyst Characterization System (AutoChem 2920 , Micromeritics , USA) equipped with a <i>mass spectrometer</i> (QIC 20, Hiden, UK) by using 0.20 g catalyst powder. ...	2920
Probing into the catalytic nature of Co/sulfated zirconia for selective reduction of ...dicp.ac.cn	N Li, A Wang, M Zheng, X Wang, R Cheng, T Zhang - Journal of Catalysis, 2004	... Temperature-programmed reduction (TPR) experiments were carried out with a Micromeritics AutoChem II 2920 automated catalyst characterization system using an H ₂ ... NO-TPD was conducted on a flowing reaction system using a <i>mass spectrometer</i> (Omini-star, GSD-300) as ...	2920
Promotional effects of noble metal addition to cobalt Fischer-Tropsch synthesis ...	D Xu, P Dai, Q Guo, W Li - Reaction Kinetics and Catalysis Letters, 2008	... experiments of adsorbed CO were performed using a Micromeritics AutoChem 2910 instrument at atmospheric pressure. The Page 3. DONGYAN XU et al.: NOBLE METAL 369 fragments m/e 2, 16, 18, 28 and 44 were recorded by a quadrupole <i>mass spectrometer</i> (Ominister 300 ...	2910
Properties of alkali-promoted Cu-MgO catalysts and their activity for methanol ...	S Goodarznia, KJ Smith - Journal of Molecular Catalysis A: Chemical, 2010	... A TCD attached to a Micromeritics AutoChem II chemisorption analyzer was used to detect the consumption of N ₂ O and Cu dispersion was ... The gas flow lines between the pre-heater and the reactor as well between the reactor and the <i>mass spectrometer</i> were held at the same ...	2920
Pt/H-ZSM-12 as a catalyst for the hydroisomerization of C ₅ -C ₇ n-alkanes and simultaneous saturation of benzene	Gopal, S., Smirniotis, P.G., Applied Catalysis A: General, 247 (1), p.113-123, Jul 2003	...determined by pulse hydrogen chemisorption using a Micromeritics AutoChem 2910 automated catalyst characterization system...Hewlett-Packard, 5890 Series II) equipped with a <i>mass spectrometer</i> (Hewlett-Packard, 5972 Series II). Separation...	2910
Pulse-response TAP studies of the reverse water-gas shift reaction over a Pt/CeO ₂ catalyst	Goguet, A., Shekhtman, S.O., Burch, R., Hardacre, C., Meunier, F.C., Yablonsky, G.S., Journal of Catalysis, 237 (1), p.102-110, Jan 2006	...measured by BET (Micromeritics ASAP 2010) and...H ₂ chemisorption (Micromeritics AutoChem 2910) and was found...100C quadrupole <i>mass spectrometer</i> . The temperature...extracted from the <i>mass spectrometer</i> data using standard...	2910
Quantification of Bronsted Acid Sites in Microporous Catalysts by a Combined FTIR ...	GVA Martins, G Berlier, C Bisio, S Coluccia, HO ... - 2008	... tubular furnace. The measurement was carried out on the activated catalysts using a Micromeritics TPD/TPR 2900 analyzer equipped with a TC detector and coupled with a Hiden HPR 20 <i>mass spectrometer</i> . The activated samples ...	2900
Quantification of metallic area of high dispersed copper on ZSM-5 catalyst by TPD ...	MCN Amorim de Carvalho, FB Passos, M ... - Catalysis ..., 2002	... H ₂ TPD experiment was performed using a Micromeritics TPD/TPR 2900 apparatus, equipped with a Baltzer Mass Quadrupole, where the sample ... The degree of reduction of copper was also determined from the TPR data, coupled to <i>mass spectrometer</i> , previous to the TPD ...	2900
Reaction performance and characterization of Co/Al ₂ O ₃ Fischer-Tropsch ...	D Xu, W Li, H Duan, Q Ge, H Xu - Catalysis Letters, 2005	... Temperature programmed surface reaction (TPSR) of adsorbed CO TPSR experiments of adsorbed CO were performed using Micromeritics AutoChem 2910 instrument ... The fragments m/e=2, 16, 18, 28 and 44 were recorded by a quadrupole <i>mass spectrometer</i> (Ominister 300 ...	2910

Reactivity of LSCF perovskites	Scott, S.P., Mantzavinos, D., Hartley, A., Sahibzada, M., Metcalfe, I.S. , Solid State Ionics, 152, p.777-781, Dec 2002	...Experiments were performed using a Micromeritics TPR/TPD 2900 machine fitted with a thermoconductivity...units. A Spectra Microvision <u>mass spectrometer</u> was attached to analyse...using a Spectra Microvision <u>mass spectrometer</u> attached to the outlet gas...	2900
Reducibility of catalyzed cerium–praseodymium mixed oxides	W Chun, GW Graham, JA Lupescu, RW McCabe, MM ... - Catalysis Letters, 2006	... Temperature-programmed reduction (TPR) measurements were performed with a Micromeritics AutoChem II 2920 system. ... C/s) while concentrations of the three hydrocarbon species exiting the sample were monitored with a chemical ionization <u>mass spectrometer</u> [8]. Although ...	2920
Reduction of sulfur dioxide by carbon monoxide over doped nanophase cerium ...kth.se	AEC Palmqvist, MFM Zwinkels, Y Zhang, SG ... - Nanostructured ..., 1997	... with a Micromeritics TPD TPR 2900 Chemisorption Analyzer. A series of activity tests was carried out with a nearly stoichiometric reactant gas mixture containing 3.20 CO and 1.65SO ₂ inHe. The composition of outlet gases were analyzed with a Balzers <u>mass spectrometer</u> model ...	2900
Regeneration of CuO-ZnO-Al₂O₃/[gamma]-Al₂O₃ catalyst in the direct synthesis of ...	I Sierra, J Erefña, AT Aguayo, JM Arandes, J ... - Applied Catalysis B: ..., 2009	... The metallic surface area, determined by N ₂ O chemisorption (in a Micromeritics AutoChem 2920 coupled to a Pfeiffer Omnistar <u>mass spectrometer</u>), is 11.7 m ² (g of catalyst) ⁻¹ . The physical properties, measured by N ₂ adsorption–desorption (Micromeritics ASAP 2000) are ...	2920
Regeneration of CuO-ZnO-Al₂O₃/±c-Al₂O₃ catalyst in the direct synthesis of dimethyl ether	Sierra, I., Erena, J., Aguayo, A.T., Arandes, J.M., Bilbao, J. , Applied Catalysis B, Environmental, 94 (1), p.108-116, Feb 2010	...chemisorption (in a Micromeritics AutoChem 2920 coupled to a Pfeiffer Omnistar <u>mass spectrometer</u>), is 11.7m ² ...Pfeiffer Omnistar <u>mass spectrometer</u> [40], a total...coupled to a <u>mass spectrometer</u> (Thermostar from...	2920
Role of adsorbed NO in N₂O decomposition over iron-containing ZSM-5 catalysts ...	DA Bulushev, A Renken, L Kiwi-Minsker - J. Phys. Chem. B, 2006	... Catalytic Activity Measurements. Catalytic activity measurements and temperature- programmed studies were performed with a Micromeritics AutoChem 2910 analyzer. A ThermoStar 200 (Pfeiffer Vacuum) quadrupole <u>mass spectrometer</u> was used for gas analysis. ...	2910
Role of potassium on the structure and activity of alumina-supported vanadium oxide catalysts for propane oxidative...	Garcia Cortez, G., Fierro, J.L.G., Banares, M.A. , Catalysis Today, 78 (1), p.219-228, Feb 2003	...was measured with a Micromeritics ASAP-2000 apparatus...apparatus model TPR/TPD- 2900 fitted with a TCD...coupled to a quadrupole <u>mass spectrometer</u> equipment, model Balzers...monitored with an on-line <u>mass spectrometer</u> . The reaction products...	2900
Roles of chlorine in the CO hydrogenation to C₂-oxygenates over Rh-Mn-Li/SiO₂ catalysts	Jiang, D., Ding, Y., Pan, Z., Li, X., Jiao, G., Li, J., Chen, W., Luo, H. , Applied Catalysis A, General, 331, p.70-77, Jan 2007	...performed on a Micromeritics AutoChem 2910 apparatus...with a quadrupole <u>mass spectrometer</u> (Balzers OmniStar...z=28) with the <u>mass spectrometer</u> . 2.2.6 Temperature-programmed...recorded with the <u>mass spectrometer</u> . 2.3 Catalytic...	2910
Selective catalytic oxidation of ammonia to nitrogen at low temperature on Pt/CuO/Al₂O₃	Olofsson, G., Reine Wallenberg, L., Andersson, A. , Journal of Catalysis, 230 (1), p.1-13, Feb 2005	...adsorption isotherm, recorded on a Micromeritics ASAP 2400 instrument at liquid...microreactor connected to a UTI 100C <u>mass spectrometer</u> [20]. Fifty milligrams of...TPR) was performed on a Micromeritics TPD/TPR 2900 instrument. The temperature...	2900

<p>Selective catalytic reduction of nitric oxide with ammonia on copper (II) ion- ...</p>	<p>W Arous, H Tounsi, S Djemel, A Ghorbel, G ... - Catalysis ..., 2005</p>	<p>... Temperature programmed reduction by hydrogen (H₂-TPR) was carried out with a Micromeritics AutoChem 2910 apparatus using H₂ (3 ... The gas composition was monitored by sampling on line with a quadruple <i>mass spectrometer</i> (Pfeiffer Omnistar), calibrated with standard ...</p>	<p>2910</p>
<p>Selective catalytic reduction of nitric oxide with ammonia on Fe-ZSM-5 catalysts prepared by different methods</p>	<p>G Delahay, D Valade, A Guzmán-Vargas, B ... - Applied Catalysis B, ..., 2005</p>	<p>... TPR by H₂/Ar (3/97, vol.%/vol.%) was carried out with a Micromeritics AutoChem 2910 apparatus using TCD detection. ... The effluent composition was monitored continuously and by sampling on line to a quadruple <i>mass spectrometer</i> (Pfeiffer Omnistar) equipped with ...</p>	<p>2910</p>
<p>Selective CO removal in a H₂-rich stream over supported Ru catalysts for the polymer electrolyte membrane fuel cell...</p>	<p>Kim, Y.H., Park, E.D., Lee, H.C., Lee, D., Applied Catalysis A, General, 366 (2), p.363-369, Sep 2009</p>	<p>...conducted in an AutoChem 2910 unit (Micromeritics) equipped with...conducted in an AutoChem 2910 unit (Micromeritics...conducted in an AutoChem 2910 unit (Micromeritics...and an online <i>mass spectrometer</i> (QMS 200, Pfeiffer...</p>	<p>2910</p>
<p>Selective oxidation of CO in hydrogen-rich stream over Cu-Ce catalyst promoted ...gwangju.ac.kr</p>	<p>J Won Park, J Hyeok Jeong, WL Yoon, CS Kim, ... - International Journal of ..., 2005</p>	<p>... CO-TPR) and temperature-programmed oxidation (TPO) techniques, using a Balzers GSD 300T <i>mass spectrometer</i> (CO, CO₂ ... H₂-TPR investigation was performed on a conventional temperature programming system (AutoChem 2910, Micromeritics) equipped with a ...</p>	<p>2910</p>
<p>Selective reduction of NO with CO over titania supported transition metal oxide ...</p>	<p>PM Srekanth, PG Smirniotis - Catalysis Letters, 2008</p>	<p>... The ammonia TPD experiments were performed on a Micromeritics AutoChem 2910 instrument using 50 mg of catalyst ... The reactants and products were analyzed on-line using a Quadrapole <i>mass spectrometer</i> (MKS PPT- RGA), chemiluminescence detector (Eco Physics CLD ...</p>	<p>2910</p>
<p>Significant effect of acidity on catalytic behaviors of Cs-substituted polyoxometalates for oxidative dehydrogenation of...</p>	<p>Sun, M., Zhang, J., Cao, C., Zhang, Q., Wang, Y., Wan, H., Applied Catalysis A, General, 349 (1), p.212-221, Oct 2008</p>	<p>...and were carried out with a Micromeritics TriStar 3000 surface area...NH₃-TPD) were performed on Micromeritics AutoChem 2920 II instrument. Typically...by ThermoStar GSD 301 T2 <i>mass spectrometer</i>. Because the parent peak...</p>	<p>2920</p>
<p>Simultaneous Removal of NO_x and Mercury in Low Temperature Selective ...</p>	<p>NG Pinto, PG Smirniotis - 2006 - osti.gov</p>	<p>... were carried out from 353–1223 K on a Micromeritics AutoChem 2910 instrument ... were performed on a Micromeritics Tristar 3000 Porosimeter (Micromeritics Instrument Corporation ... at 673 K. The products were analyzed on-line using a Quadrapole <i>mass spectrometer</i> (MKS PPT ...</p>	<p>2910</p>
<p>Single and combined deactivating effect of alkali metals and HCl on commercial ...</p>	<p>L Lisi, G Lasorella, S Malloggi, G Russo - Applied Catalysis B, ..., 2004</p>	<p>... Temperature programmed desorption (TPD) of NH₃ was carried out using a Micromeritics TPD/TPR 2900 analyser equipped with a TC detector and coupled with a Hiden HPR 20 <i>mass spectrometer</i>. After a pre-treatment in ...</p>	<p>2900</p>
<p>Skeletal isomerization of unsaturated fatty acids: the role of mesopores in HBeta ...</p>	<p>S Zhang, ZC Zhang - Catalysis Letters, 2007</p>	<p>... The measurement was conducted on a Micromeritics AutoChem 2910 system. ... from room temperature with a temperature ramp of 10 °C/min to 700 °C. Desorbed species were monitored with a calibrated thermoconductivity detector (TCD) as well as a <i>mass spectrometer</i>. ...</p>	<p>2910</p>
<p>Sol-gel derived mesoporous Cr/Al₂O₃ catalysts for SCR of NO by ammonia</p>	<p>F Ayari, M Mhamdi, G Delahay, A Ghorbel - Journal of Porous Materials</p>	<p>... temperature ramped from ambient to 1,000 °C at 15 °C/min) was performed with 0.04 g of catalyst using a Micromeritics AutoChem 2910 Analyser ... Effluents gases were analysed after reaching a steady state by means of <i>Mass spectrometer</i> piloted with software (Quadstar, 32 Bits ...</p>	<p>2910</p>

Sol–Gel Synthesis of MoO ₃ /SiO ₂ Composite for Catalytic Application in ...	AP Amrute, A Bordoloi, N Lucas, K Palraj, SB Halligudi - Catalysis Letters, 2008	... The total acidities of the catalysts were measured by temperature programmed desorption of NH ₃ (NH ₃ -TPD) using a Micromeritics AutoChem-2910 instrument. ... The products were identified by GC-MS (QP- 5000 <i>Mass spectrometer</i> , GC-17A Gas Chromatograph) analysis. ...	2910
Stability of lanthanum oxide-based H ₂ S sorbents in realistic fuel processor/fuel cell ...	I Valsamakis, R Si, M Flytzani-Stephanopoulos - Journal of Power Sources, 2009	... The sorbent BET surface areas were measured by single-point N ₂ adsorption/desorption cycles using a Micromeritics model AutoChem II 2920 ... concentrations of H ₂ O, CO and CO ₂ in the outlet gas were monitored on-line by a quadrupole <i>mass spectrometer</i> and the ...	2920
Steam reforming of liquid hydrocarbon fuels for micro-fuel cells. Pre-reforming of model jet fuels over supported metal...	Zheng, J., Strohm, J.J., Song, C. , Fuel Processing Technology, 89 (4), p.440-448, Apr 2008	...an automated catalyst characterization unit (Micromeritics AutoChem 2910) to determine the metal dispersion and metal...GC coupled with a Shimadzu QP-5000 quadrupole <i>mass spectrometer</i> (MS) detector. The GC is equipped with a capillary...	2910
Structural changes of nano-Pt particles during thermal ageing: Support-induced ...	JP Dacquin, M Cabié, CR Henry, C Lancelot, C ... - Journal of Catalysis, 2010	... Hydrogen temperature-programmed reduction (H ₂ -TPR) was carried out in a Micromeritics AutoChem II 2920 apparatus (5 vol.% H ₂ /Ar). ... analysed with a µGC Varian CP-4900 chromatograph fitted with two thermal conductivity detectors and a Balzer <i>mass spectrometer</i> ...	2920
Structure and Electronic Properties of Ca-Doped CeO ₂ and Implications ...kth.se	S De Carolis, JL Pascual, LGM Pettersson, M ... - Journal of Physical ..., 1999 - ict.kth.se	... were evaluated with a Micromeritics TPD/ TPR 2900 Chemisorption Analyzer using a nearly stoichiometric reactant gas mixture containing 3.20% CO and 1.65% SO ₂ in He. The composition of outlet gas was analyzed with a Balzers <i>mass spectrometer</i> model QMG421C, and ...	2900
Study of catalytic behaviour and deactivation of vanadyl-aluminum binary ...	FM Bautista, JM Campelo, D Luna, J Luque, JM ... - Chemical Engineering ..., 2006	... TPR experiments were performed in a Micromeritics TPD/TPR 2900 analyser [6]. Samples of 50 mg were first treated in Ar at 100 °C for ... 10 °C/min (temperature range, 30–1000 °C). The CO ₂ signal was analysed with an on-line quadrupole <i>mass spectrometer</i> (Pfeiffer Vacuum ...	2900
STUDY OF N ₂ O DECOMPOSITION OVER FE-ZSM-5 WITH TRANSIENT ...epfl.ch	P PREChTL - biblion.epfl.ch	... Micromeritics AutoChem 2910 Analyzer 58 ... Potential IPCC Intergovernmental Panel on Climate Change IR Infrared MCT Mercury Cadmium Telluride MFI Crystalline structure of ZSM-5 zeolite (Mobil Five) MMO Methane Monooxygenase MS <i>Mass spectrometer</i> NSCR Non ...	2910
Study of the origin of the deactivation of a Pt/CeO ₂ catalyst during reverse water ...	A Goguet, F Meunier, JP Breen, R Burch, MI Petch, A ... - Journal of Catalysis, 2004	... 2010) and was found to be 180 m ² g ⁻¹ . The Pt dispersion was measured by H ₂ chemisorption (Micromeritics AutoChem 2910) and ... 5 °C min ⁻¹ . The CO and CO ₂ concentrations were followed at the outlet of the reactor with a quadrupole <i>mass spectrometer</i> (VG Gaslab300 ...	2910
Study of the temperature-programmed oxidative degradation of hydrocarbons over ...	Jl Gutiérrez-Ortiz, B de Rivas, R López-Fonseca ... - Journal of thermal ..., 2007	... investigated. The effluent stream was analysed by a TCD coupled to a <i>mass spectrometer</i> (HAL Quadrupole <i>Mass spectrometer</i> , Hyden Analytical). The experiments were conducted on a Micromeritics AutoChem 2910 instrument. ...	2910
Study on Copper-based Catalysts for Synthesis of N, N'-bis (1, 4-dimethylpentyl)- ...	ZD Pan, YJ Ding, L Yan, XM Li, GP Jiao, HY Luo - Catalysis Letters, 2008	... monitoring simultaneously the signal of H ₂ (m/z = 2) with a <i>mass spectrometer</i> detector (Prisma). H ₂ temperature programmed reduction (H ₂ -TPR) measurements were performed on a Micromeritics AutoChem 2910 apparatus. ...	2910

Study on Ni-Re-K/Al₂O₃ catalysts for synthesis of N, N'-di-sec-butyl p-phenylene ...	Z Pan, Y Ding, D Jiang, X Li, G Jiao, H Luo - Applied Catalysis A, General, 2007	... Temperature programmed desorption of ammonia (NH ₃ -TPD) was performed in a Micromeritics AutoChem 2910 a ramp of 10 K/min in a helium flow of 40 ml/min and the NH ₃ (m/z = 16) was monitored simultaneously with a quadrupole <i>mass spectrometer</i> detector (Balzers ...	2910
Study on the Ti and Al incorporation into the MFI zeolitic structure	G Ovejero, R Grieken, MA Uguina, DP Serrano, ... - Journal of Materials ..., 1998	... 1 and 2. carried out with a Micromeritics TPD/TPR 2900 apparatus. The sample was first outgassed by thermal treatment, from Samples 4–12. ... Person et al.22 to synthesize silicalite-1. This method allows to continuously using a quadrupole <i>mass spectrometer</i> (Hiden ...	2900
Sulphur poisoning of palladium catalysts used for methane combustion: Effect of ...	LS Escandón, S Ordóñez, A Vega, FV Díez - Journal of Hazardous ..., 2008	... Temperature-programmed desorption analyses were carried out using a Micromeritics TPD/TPR 2900 Analyzer, operating at ambient pressure. ... room temperature to 900 °C at 10 °C min ⁻¹ , and the gas leaving the reactor was analysed by a <i>mass spectrometer</i> (GASLAB 300 ...	2900
Sulphur poisoning of transition metal oxides used as catalysts for methane ...	S Ordóñez, JR Paredes, FV Díez - Applied Catalysis A, General, 2008	... Temperature-programmed desorption was carried out in a Micromeritics TPD/TPR 2900 apparatus connected to a TCD or a MS detector (Gaslab-300). Samples of 10 mg of catalysts were heated from 50 to 1000 °C at 10 °C/min in a flow of 0.1 L/min of pure He. ...	2900
Supported bimetallic AuRh/±c-Al₂O₃ nanocatalyst for the selective catalytic reduction of NO by propylene	Liu, L., Guan, X., Li, Z., Zi, X., Dai, H., He, H. , Applied Catalysis B, Environmental, 90 (1), p.1-9, Jul 2009	...2020 apparatus from Micromeritics . The samples were...O ₂ -H ₂ titration on AutoChem 2920 II chemical adsorption apparatus from Micromeritics. The 0.2g of catalyst...catalysts was performed on AutoChem 2920 II chemical adsorption...on-line by a quadrupole <i>mass spectrometer</i> (HIDEN HPR20 equipped...)	2920
Supported bimetallic AuRh/γ-Al₂O₃ nanocatalyst for the selective catalytic ...	L Liu, X Guan, Z Li, X Zi, H Dai, H He - Applied Catalysis B, Environmental, 2009	... H ₂ -TPR of catalysts was performed on AutoChem 2920 II chemical adsorption apparatus from Micromeritics by using ... z = 32), N ₂ (m/z = 28), N ₂ O (m/z = 44) and NO ₂ (m/z = 46) in NO-TPD process were monitored on-line by a quadrupole <i>mass spectrometer</i> (HIDEN HPR20 ...	2920
Supported metal particles from LDH nanocomposite precursors: control of the ...	C Gerardin, D Kostadinova, N Sanson, B Coq, D Tichit - Chem. Mater, 2005	... K in a stream of He or synthetic air (flow: 20 cm ³ min ⁻¹). A Balzers QMS 421 quadrupole <i>mass spectrometer</i> equipped with ... The H ₂ temperature-programmed reduction (TPR) analyses were done using a Micromeritics AutoChem 2910 instrument with a TCD detection (m = 30 ...	2910
Surface characterization of supported Pd catalysts activated with chiral hydrogen ...	MA Aramendia, Y Aviles, V Borau, C Jimenez, JM ... - Langmuir, 1999	... TPD-TCD Experiments. Temperature-programmed desorption experiments were carried out on a Micromeritics TPD/TPR 2900 instrument. ... The oven outlet was connected to the <i>mass spectrometer</i> probe to collect samples in a continuous fashion. ...	2900
Surface characterization studies of TiO₂ supported manganese oxide catalysts for ...uc.edu	PR Ettireddy, N Ettireddy, S Mamedov, P ... - Applied Catalysis B, ..., 2007	... The oxygen uptake was quantified by a TCD connected to a 2910 AutoChem I (Micromeritics instrument) The reactants and products were analyzed on-line using a Quadrupole <i>mass spectrometer</i> (MKS PPT-RGA), and a NO _x analyzer (Eco Physics CLD 70S). ...	2910
Surface properties and catalytic performance for ethane combustion of La₁- ...	YN Lee, RM Lago, JLG Fierro, V Cortés, F ... - Applied Catalysis A, ..., 2001	... Temperature programmed reduction (TPR) and O ₂ temperature programmed desorption (TPO) profiles were obtained in a Micromeritics 2900 instrument. ... at 10 K min ⁻¹ and the desorption products O ₂ , CO ₂ and H ₂ O monitored by a <i>mass spectrometer</i> detector Balzers QMG ...	2900

Surface reconstruction of supported Pd on LaCoO ₃ : Consequences on the catalytic properties in the decomposition of N ₂ O	Dacquin, J.P., Dujardin, C., Granger, P., Journal of Catalysis, 253 (1), p.37-49, Jan 2008	...Temperature-programmed reduction (TPR) was carried out in a Micromeritics AutoChem II 2920 (5 vol% H ₂ /Ar). In situ X-ray diffraction...two thermal conductivity detectors and a Balzer <i>mass spectrometer</i> for the detection and the quantification of O ₂ and...	2920
SURVIVAL OF LIGNIN-DERIVED STRUCTURAL UNITS IN ANCIENT COALIFIED WOOD SAMPLES.	6-Mar	...data not available Pyrolysis-gas chromatography-mass spectrometry was performed on a Dupont 4908 gas chromatograph- <i>mass spectrometer</i> system interfaced with a Technivent Vector 1 data system and a Chemical Data Systems model 120 pyroprobe. Pyrolysis...	
Synthesis and characterization of MgO-B ₂ O ₃ mixed oxides prepared by ...rsc.org	MA Aramendía, V Boráu, C Jiménez, JM Marinas ... - Journal of Materials ..., 1999	... the boron atoms are considered located in a trigonal or Micromeritics TPD/TPR 2900 —VG Sensorlab quadrupole tetragonal environment within the magnesium network. As we <i>mass spectrometer</i> . The optimum TPD conditions were as ...	2900
Synthesis and characterization of ZrO ₂ as an acid–base catalyst ...rsc.org	MA Aramendía, V Boráu, C Jiménez, JM Marinas ... - Journal of the Chemical ..., 1997	... TPD–MS experiments TPD»MS experiments were carried out on a Micromeritics TPD/TPR 2900 instrument on line with a VG Sensorlab quadrupole <i>mass spectrometer</i> . The optimum TPD conditions were as follows: heating ...	2900
Synthesis and properties of PdSn/Al ₂ O ₃ and PdSn/SiO ₂ prepared by solvated metal atom dispersed method	Cardenas, G., Oliva, R., Reyes, P., Rivas, B.L., Journal of Molecular Catalysis A: Chemical, 191 (1), p.75-86, Jan 2003	...343 K was carried by a pulse method in a TPD/TPR 2900 Micromeritics system provided with a thermal conductivity detector...reactants and products were carried out by on line <i>mass spectrometer</i> HIDDEN HAL 200. The reactor was kept in a furnace...	2900
Synthesis of alkoxide-derived V-Nb catalysts prepared by sol–gel route	M Catauro, C Pagliuca, L Lisi, G Ruoppolo - Thermochimica Acta, 2002	... was employed for the BET measurement of surface areas by N ₂ adsorption at 77 K. Temperature-programmed reduction (TPR) was carried out using of a Micromeritics TPD/TPR 2900 analyzer equipped with a TCD and coupled with a Hiden HPR 20 <i>mass spectrometer</i>	2900
Synthesis of Biodiesel via Deoxygenation of Stearic Acid over Supported Pd/C ...	S Lestari, I Simakova, A Tokarev, P Mäki-Arvela, K ... - Catalysis Letters, 2008	... The metal dispersion was determined by CO pulse chemisorption using AutoChem 1900 (Micromeritics). ... The product identification was validated with a gas chromatograph– <i>mass spectrometer</i> (GC–MS). 248 S. Lestari et al. 123 Page 3. 2.3.2 Gas Phase Analysis ...	2900
Synthesis of camphene from α-pinene using SO ₃ 2–functionalized MCM-41 as ...	M Roman-Aguirre, YP Gochi, AR Sanchez, L de ... - Applied Catalysis A, ..., 2007	... The acid sites per gram of each catalyst were quantified by thermal desorption of NH ₃ in a Micromeritics AutoChem 2910 analyzer. ... present in the samples were identified by analysis in a Thermofinigan GC Top 8000/Voyager MS gas chromatograph/ <i>mass spectrometer</i> system. ...	2910
Synthesis of gasoline-range hydrocarbons over Mo/HZSM-5 catalysts	S Liu, AC Gujar, P Thomas, H Toghiani, MG ... - Applied Catalysis A, ..., 2009	... Catalyst characterization. Temperature programmed reduction/reaction (TPR) of 10%Mo/HZSM-5 was conducted with a Micromeritics AutoChem 2910 apparatus combined with a Dycor Dymaxion Quadrapole <i>Mass spectrometer</i> from Ametek Process Instruments. ...	2910
Synthesis of LaFeO ₃ catalytic materials and their sensing propertiesscichina.com	SL Bai, BJ Shi, LJ Ma, PC Yang, ZY Liu, DQ Li, ... - Science in China ..., 2009	... sensing materi- als' surface, TPD experiments were performed on La- FeO ₃ and 4% MgO-coated LaFeO ₃ nanocomposites prepared by citric acid method by a Micromeritics TPD/TPR 2900 analyzer equipped with a TC detector and coupled with a HPR 20 <i>mass spectrometer</i>	2900

Synthesis of reactive nano-Fe/Pd bimetallic system-impregnated activated carbon ...	H Choi, SR Al-Abed, S Agarwal, DD Dionysiou - Chem. Mater, 2008	... H ₂ -temperature programmed reduction (H ₂ -TPR) technique was adopted on AutoChem 2910 TPD/TPR instrument (Micromeritics) to investigate ... D-8 naphthalene in dichloromethane, and analyzed in a gas chromatograph (GC, HP 6890)/ <i>mass spectrometer</i> (MS, HP ...	2910
Synthesis of ZSM-5 zeolite in fluoride media: an innovative approach to tailor both crystal size and acidity	Louis, B., Kiwi-Minsker, L., Microporous and Mesoporous Materials, 74 (1), p.171-178, Sep 2004	...properties. The measurements were performed in a Micromeritics AutoChem 2910 analyser provided with a quartz plug-flow reactor. A ThermoStar 200 (Pfeiffer Vacuum) mass-spectrometer was used to analyse the gas-phase composition...	2910
Synthesis, characterization and activation of quaternary layered double hydroxides ...	NN Das, R Das - Reaction Kinetics, Mechanisms and Catalysis	... The gases evolved during decomposition were analyzed by an online Leybold Transpector SQX quadrupole <i>mass spectrometer</i> C. Temperature programmed reduction (TPR) of the calcined samples were performed in a AutoChem 2910 from Micromeritics as described ...	2910
TAP reactor study of the deep oxidation of propane using cobalt oxide and gold- ...	B Solsona, T Garcia, GJ Hutchings, SH Taylor, ... - Applied Catalysis A, ..., 2009	... Temperature-programmed reduction was carried out in a Micromeritics AutoChem 2910 equipped with a TCD detector. ... recorded at the reactor outlet by three PC interfaced Balzers QMA124 quadrupole <i>mass spectrometers</i> (QMS) in line; a fourth <i>mass spectrometer</i> is positioned ...	2910
Temperature-programmed desorption study of molecular oxygen adsorbed on MFI- ...	MH Kim, SJ Kim, SB Hong, G Seo, YS Uh - Korean Journal of Chemical ..., 1998	... Temperature-programmed desorption (TPD) of O ₂ was re- corded on a Micromeritics TPD/TPR 2900 analyzer. ... 373 to 873 K with heating rates ranging from 5 to 30 K. In all TPD experiments the desorbed gas was identified as O ₂ alone by a Balzers MSC 200 <i>mass spectrometer</i>	2900
Temperature-programmed desorption study of Re/\pm-Al₂O₃ catalysts prepared from Re₂(CO)₁₀ precursor	Raty, J., Pakkanen, T.A., Applied Catalysis A: General, 208 (1), p.169-175, Feb 2001	...TPD) were performed with a Micromeritics AutoChem 2910 analyser. A thermal...instrument to a quadrupole <i>mass spectrometer</i> (HP 5920). A typical TPD...catalyst (8.9 wt.%). shows the <i>mass spectrometer</i> signal from the catalyst...	2910
The alteration of the performance of field-aged Pd-based TWCs towards CO and C₃H₆ oxidation	Heo, I., Choung, J.W., Kim, P.S., Nam, I.S., Song, Y.I., In, C.B., Yeo, G.K., Applied Catalysis B, Environmental, 92 (1), p.114-125, Oct 2009	...volumetric methods (Micromeritics , ASAP 2010...chemisorption method (AutoChem II 2920 , Micromeritics). Details are...H ₂ /Ar with AutoChem II 2920 . H ₂ temperature...Packard) and a <i>mass spectrometer</i> (QMI422, Pfeiffer...	2920
The catalytic reforming of bio-ethanol over SiO₂ supported ZnO catalysts: The role ...	E Seker - International Journal of Hydrogen Energy, 2008	... source Hg or less. In addition, CO ₂ TPD was performed to measure the basicity of all catalysts using Micromeritics AutoChem 2910 equipped with an inline Balzers Thermostar GS300 quadrupole <i>mass spectrometer</i> . 0.1 g of a ...	2910
The effect of metal ions in MNaY-zeolites for the adsorptive removal of ...	YH Kim, HC Woo, D Lee, HC Lee, ED Park - Korean Journal of Chemical ..., 2009	... desorption (TPD) of THT adsorbed on the adsorbents was conducted over 30 mg of sample at a heating rate of 10 K/min monitoring thermal conductivity detector (TCD) and mass signals using an AutoChem 2910 unit (Micromeritics) and a <i>mass spectrometer</i> (QMS 200 ...	2910

<p>The interaction of N₂O with ZSM-5-type zeolites: A transient, multipulse ...</p>	<p>A Ates, A Reitzmann - Journal of Catalysis, 2005</p>	<p>... All transient-response studies were performed in an apparatus containing a quartz glass reactor (AutoChem 2910, Micromeritics). A quadruple <i>mass spectrometer</i> (QMS 422; Pfeiffer Vacuum) was used in an on-line mode to determine the composition of the gas phase. ...</p>	<p>2910</p>
<p>The promoted effect of UV irradiation on preferential oxidation of CO in an H₂-rich stream over Au/TiO₂</p>	<p>W Dai, X Zheng, H Yang, X Chen, X Wang, P Liu, ... - Journal of Power ..., 2009</p>	<p>... However, no other product in outlet was observed except that H₂O and CO₂ in all reaction systems. 2.4. Temperature program desorption (TPD). Temperature program desorption (TPD) of Au/TiO₂ was tested in Micromeritics AutoChem 2910 instrument. ...</p>	<p>2910</p>
<p>The promotion effects of Mn, Li and Fe on the selectivity for the synthesis of C₂ ...</p>	<p>HM Yin, YJ Ding, HY Luo, WM Chen, ... - Natural gas conversion ..., 2004</p>	<p>... CO-TPD experiments were performed on Micromeritics AutoChem 2910. After CO adsorption saturation, the catalyst bed was swept with He for 5 min. Each experiment was performed in a He flow (flow rate= 20 ml/min) with a quadruple <i>mass spectrometer</i> (QMS, Balzers ...</p>	<p>2910</p>
<p>The quality of SiO₂-coatings on flame-made TiO₂-based nanoparticles135.196.210.195</p>	<p>A Teleki, MK Akhtar, SE Pratsinis - matrix - 135.196.210.195</p>	<p>... The chemisorption of isopropanol on FSP-made particles was investigated on a Micromeritics AutoChem II 2920 unit. ... The off-gases from the AutoChem were analyzed by a <i>mass spectrometer</i> (MS; Thermo Star, Pfeiffer Vacuum, SEM and emission mode). ...</p>	<p>2920</p>
<p>The reactivity of ruthenium mono (bipyridine) carbonyl complexes in an alcoholic ...</p>	<p>S Luukkanen, M Haukka, O Laine, T Venäläinen, ... - Inorganica Chimica ..., 2002</p>	<p>... TPD profiles of the ruthenium bipyridine complexes were recorded on a Micromeritics TPD/TPR 2900 instrument under a He-flow of 10 ml min ... The EI ionisation mass spectra were recorded with a JEOL JMS D300 magnetic sector <i>mass spectrometer</i> and the LD ionisation mass ...</p>	<p>2900</p>
<p>The reactivity of ruthenium mono(bipyridine) carbonyl complexes in an alcoholic solution of alkali metal carbonates</p>	<p>Luukkanen, S., Haukka, M., Laine, O., Venäläinen, T., Vainiotalo, P., Pakkanen, T.A., Inorganica Chimica Acta, 332 (1), p.25-29, Apr 2002</p>	<p>...were recorded on a Micromeritics TPD/TPR 2900 instrument under...magnetic sector <i>mass spectrometer</i> and the LD ionisation...time-of-flight <i>mass spectrometer</i>. Polymeric samples...introduced into the <i>mass spectrometer</i> under an argon...</p>	<p>2900</p>
<p>The Use of a Jet-Stirred Continuously Stirred Tank Reactor (CSTR) to Study the ...</p>	<p>GA Foulds, BG Charlton, BT Leeb, JC ... - ... gas conversion four, 1997</p>	<p>... A portion of the exit gas from the reactor (15ml/min NTP) was diverted to a quadrupole <i>mass spectrometer</i> to measure the concentration of the ... TPR analysis were carried out in a Micromeritics TPD/TPR 2900 apparatus, using~ 50mg of the sample in a 10% H₂/Ar flow at 10 C/min ...</p>	<p>2900</p>
<p>Thermally reduced ruthenium nanoparticles as a highly active ...nus.edu.sg</p>	<p>F Su, L Lv, FY Lee, T Liu, AI Cooper, XS Zhao - Science, 2007 - nus.edu.sg</p>	<p>... an inductive-coupled plasma atomic <i>mass spectrometer</i> (ICP-MS) on a Perkin-Elmer ELAN6100 at a wavelength of 100.9 nm.20 H₂ chemisorption on Ru catalysts was attempted to measure using various methods such as Micromeritics AutoChem II 2920 automated catalyst ...</p>	<p>2920</p>
<p>TiO₂ supported vanadyl phosphate as catalyst for oxidative dehydrogenation of ...</p>	<p>P Ciambelli, P Galli, L Lisi, MA Massucci, P ... - Applied Catalysis A, ..., 2000</p>	<p>... Temperature Programmed Reduction (TPR) with hydrogen and Temperature Programmed Desorption (TPD) of NH₃ were carried out using a Micromeritics TPD/TPR 2900 analyser equipped with a TC detector and coupled with a Hiden HPR 20 <i>mass spectrometer</i>. ...</p>	<p>2900</p>

Titania supported bimetallic transition metal oxides for low-temperature SCR of NO ...	PM Sreekanth, DA Pena, PG Smirniotis - Ind. Eng. Chem. Res, 2006	... The temperature-programmed reduction (H ₂ - TPR) experiments were carried out from 353 to 1223 K on a Micromeritics AutoChem 2910 instrument ... in situ by passing oxygen for 2 h at 673 K. The products were analyzed online using a Quadrupole <i>mass spectrometer</i> (MKS PPT ...	2910
Titanium oxide loaded zeolites as photocatalysts for the cyclization of ...	KV Subba Rao, B Srinivas, M Subrahmanyam - Catalysis Letters, 2003	... Temperature-programmed desorption (TPD) of ammonia experiments were carried out on an Auto-Chem 2910 (Micromeritics, USA) instrument ... Low-resolution EI mass spectra were recorded on a VG 7070H Micromass <i>mass spectrometer</i> at 473K, 70eV, with a trap current ...	2910
Total oxidation of chlorinated VOCs on supported oxide catalysts	Bertinchamps, Fabrice, Nov 2005	... primary ion beam to desorb and ionize species from a sample surface. The resulting secondary ions are accelerated into a <i>mass spectrometer</i> , where they are mass analyzed by measuring their time-of-flight from the sample surface to the detector. An image is generated...	
Total oxidation of toluene over calcined trimetallic hydroxalicates type catalysts	LA Palacio, J Velásquez, A Echavarría, A Faro, ... - Journal of Hazardous ..., 2009	... Temperature-programmed reduction with hydrogen was carried out in a AutoChem II Micromeritics equipment. ... in the literature from identification of the gases evolved during the thermal decomposition process continuously monitored with a <i>mass spectrometer</i> [19] and [20]. ...	2920
Transient multi pulse method for the determination of N₂O- interaction with ZSM-5 ...	A Ates, A Reitzmann - Reaction Kinetics and Catalysis Letters, 2005	... All catalytic experiments were performed in a fully-automated apparatus (Micromeritics, AutoChem 2910) containing a quartz glass reactor operated in the plug-flow mode. A quadrupole <i>mass spectrometer</i> (QMS 422, Pfeiffer Vacuum, Germany) was used to determine the ...	2910
Transient response method for characterization of active sites in HZSM-5 with low ...epfl.ch	L Kiwi-Minsker, DA Bulushev, A Renken - Catalysis Today, 2004	... The active sites concentration measurements, reactivity and temperature-programmed (TPD) studies were performed in a Micromeritics AutoChem 2910 analyzer provided with a quartz plug-flow reactor. A ThermoStar 200 (Pfeiffer Vacuum) mass-spectrometer was used to ...	2910
Use of test reactions for the characterisation of bimetallic Pt-Sn/Al₂O₃ catalysts	MP González-Marcos, B Iñarra, JM Guil, MA ... - Applied Catalysis A, ..., 2004	... by temperature-programmed desorption (TPD) of ammonia in a Micromeritics AutoChem 2910 , equipped ... dispersion was evaluated by H ₂ chemisorption in a Micromeritics ASAP 2010 ... detectors were: an AED, used for quantification, and a <i>mass spectrometer</i> , for identification of ...	2910
Utilization of High Specific Surface Area CuO- CeO₂ Catalysts for High ...	P Djinović, J Batista, B Čehić, A Pintar - 2009	... with CO ₂ were performed at atmospheric pressure using a Micromeritics AutoChem II 2920 ... test tube, which was inserted into an electric furnace of AutoChem II 2920 ... reactants during activity probing tests were simultaneously analyzed by <i>mass spectrometer</i> (Pfeiffer Vacuum ...	2920
Utilizing full-exchange capacity of zeolites by alkaline leaching: Preparation of Fe- ...	I Melian-Cabrera, S Espinosa, JC Groen, B v/d ... - Journal of Catalysis, 2006	... Temperature-programmed reduction (TPR) with H ₂ was performed in a Micromeritics TPD/TPR 2900 apparatus, using a high-purity mixture of 5 vol% H ₂ ... were carried out in a Mettler Toledo system (TGA/SDTA 851E) equipped with a Thermo-Star quadrupole <i>mass spectrometer</i>	2900

<p>Vanadium-metal(IV)phosphates as catalysts for the oxidative dehydrogenation of ethane</p>	<p>Lisi, L., Ruoppolo, G., Casaletto, M.P., Galli, P., Massucci, M.A., Patrono, P., Pinzari, F. , Journal of Molecular Catalysis. A, Chemical, 232 (1), p.127-134, May 2005</p>	<p>...flow. Temperature programmed reduction (TPR) was carried out using a Micromeritics TPD/TPR 2900 analyser equipped with a TCD and coupled with a Hiden HPR 20 <i>mass spectrometer</i>. The sample (100mg) was reduced by a 2% H₂/Ar mixture (25cm³min⁻¹...</p>	<p>2900</p>
<p>Vanadyl phosphate dihydrate supported on oxides for the catalytic conversion of ...</p>	<p>L Lisi, P Patrono, G Ruoppolo - Journal of Molecular Catalysis. A, ..., 2003</p>	<p>... Temperature programmed reduction (TPR) with hydrogen were carried out using a Micromeritics TPD/TPR 2900 analyser equipped with a TC detector and coupled with a Hiden HPR 20 <i>mass spectrometer</i> reducing the sample with a 2% H₂ /Ar mixture (25 cm³ min⁻¹) and ...</p>	<p>2900</p>
<p>Vapor-phase hydrogenolysis of biomass-derived lactate to 1, 2-propanediol over ...</p>	<p>L Huang, Y Zhu, H Zheng, M Du, Y Li - Applied Catalysis A, General, 2008</p>	<p>... The amount of chemisorbed hydrogen was measured using the Micromeritics Auto Chem. 2920 by temperature program desorption (TPD) technique. ... The liquid products were identified by gas-chromatograph (6890N, Agilent) with <i>mass spectrometer</i> (5973, Agilent). ...</p>	<p>2920</p>
<p>Water Vapor Effects in N₂O Decomposition over Fe-ZSM-5 Catalysts with Low ...</p>	<p>DA Bulushev, PM Prechtl, A Renken, L Kiwi- ... - Ind. Eng. Chem. ..., 2007</p>	<p>... Catalytic Activity Measurements. Catalytic activity measurements and temperature- programmed desorption studies were carried out in a Micromeritics AutoChem 2910 analyzer. A ThermoStar 200 (Pfeiffer Vacuum) quadrupole <i>mass spectrometer</i> was used for gas analysis. ...</p>	<p>2910</p>
<p>Water-gas shift reaction over supported Pt-CeOx catalysts</p>	<p>Kim, Y.T., Park, E.D., Lee, H.C., Lee, D., Lee, K.H. , Applied Catalysis B, Environmental, 90 (1), p.45-54, Jul 2009</p>	<p>...conducted in an AutoChem 2910 unit (Micromeritics) equipped with...and an on-line <i>mass spectrometer</i> (QMS 200, Pfeiffer...carried out in an AutoChem 2910 unit (Micromeritics...and an on-line <i>mass spectrometer</i> (QMS 200, Pfeiffer...</p>	<p>2910</p>
<p>XPS study of spent FCC catalyst regenerated under different conditions</p>	<p>RE Roncolato, MJB Cardoso, HS Cerqueira, YL ... - Ind. Eng. Chem. ..., 2007</p>	<p>... by the American Petroleum Institute), containing 1800 ppm of basic N and 3000 ppm of total N. TPO (temperature-programmed oxidation) was performed in a Micromeritics AutoChem 2910 equipment connected to a <i>mass spectrometer</i> Balzers Thermo Star 422 by a heated tube. ...</p>	<p>2910</p>